



XTR prod

user's guide

AATON®

AATON XTRprod User Guide

This manual was first written by Peter ABEL

ABEL CINE TECH 66 Willow Avenue Staten Island, NY 10305 USA

AATON

2 rue de la Paix

BP 3002

38000 Grenoble

FRANCE

+33 4 7642 9550

+33 4 7651 3491 fax

E-mail: support@aaton.com

Web: <http://www.aaton.com>

(c) March 2001 Aaton / Grenoble , France.

Limitation of Liability

The information contained in this manual is distributed without warranty of any kind, express or implied. To the maximum extent permitted by law, Aaton and its licensors disclaim any and all warranties, express or implied, by statute or otherwise, regarding this manual, including the fitness for a particular purpose, quality, or merchantability. Under no circumstances shall Aaton or its licensors be liable to the user of this manual or any other person for any incidental, special, or consequential damages resulting from the use of this manual or the operation of the equipment described therein, whether arising out of breach of warranty, breach of contract, or otherwise. Under no circumstances shall Aaton or its licensors be liable for any damages arising out of the operation of the equipment described in this manual, whether operated in a manner which is consistent with or contrary to the instructions contained therein, for physical abuse or misuse of the equipment. No oral or written information or advice given by Aaton or its licensors, their respective employees, distributors, dealers, or agents, shall create any warranty. Aaton and its licensors further disclaim any and all warranties, express or implied, by statute or otherwise, regarding this manual, including the fitness for a particular purpose, quality, or merchantability, regarding the equipment described in this manual, and in no event shall Aaton or its licensors be liable for any damages, including but not limited to incidental, special, or consequential damages, arising out of the use of the equipment, or any exposure of motion picture film used in the equipment.

I SYSTEM FEATURES AND CONTROLS

Front View	12
Rear View	13
Battery Side	14
Motor Side	15
LCD Control Panel - Quick Reference	16

2 THE CAMERA BODY

2.1 Lenses	20
ArriPL Lens Port	20
Installing the Lens	20
Aaton Lens Port	21
2.2 Viewing System	21
Viewfinder Options	21
Attaching the Extension Finder	22
Viewfinder Tension Adjustments	22
Adjusting the Diopter	23
The Eyepiece Shutter	24
Adjusting the Viewing Horizon	24
Viewing Screen	24
Changing the Viewing Screen	25
Adjusting the Viewing Screen	26
Aatonite Illumination	27
2.3 Mirror Shutter	27
Concept	27
Adjusting the Shutter	28
2.4 Film Gate and Pulldown Claw	29
2.5 Flange Focal Distance Adjustment	29
Concept	29
Polishing a Spacer	30
Changing the Spacer	30
Adjusting the Viewing Screen	30
Flange Focal Distances	30
2.6 Magazine	31
Installing the Magazine	31
Removing the Magazine	32
2.7 Power	33

Installing the Battery on the Camera	33
Battery Charging	33
Other Power Options	34
2.8 Motor	35
Camera Speeds	35
Using External Speed Devices	36
Electronic Inching	36
2.9 Lightmeter	37
Display	37
Operation	38
Using the Lightmeter without Running Film	38
Testing and Adjusting the Meter	38
Turning the Lightmeter Off	38
2.10 LCD Control Panel and Jog	39
The Aaton Jog	40
Understanding the Control Panel	40
Aatonite	41
AatonCode	41
ASA Setting	41
Battery Voltage	42
Camera Preset Speed	42
Camera Specific Speed	42
Speed Phasing	42
Feet or Meters	43
Footage Remaining	43
Footage Elapsed	43
Mag ID	43
New Magazine's Footage	44
Camera Software Version Number	44
2.11 LED Indicators	44
Position and Meaning of the Diodes	44
Camera Test Indicator	45
Camera Run Indicator	45
Low Battery Indicator	45
End-of-Film Warning Sequence	45
8-hours Warning Sequence	46
2.12 CCD Assists	46
Installing the Control Unit	46
The Internal Beamsplitter	47
Positioning the Beamsplitter	47

The Beamsplitter Axis Adjustment	48
The Manual Iris	48
Battery Life with CCD Assists	49
Installing the CCD Heads	49
The VSA Color CCD Assist	52
Menu Operation	53

3 THE MAGAZINE

3.1 Concept	60
3.2 Compatibility	60
DX Magazines	60
Super16 Safe	60
3.3 Pressure Plate System	61
The Picture Plate	61
The Claw Plate	61
3.4 Mag Identification System	62
Mag ID	62
Changing the ID of a Magazine	62
3.5 Loading	63
Feed Side - In the Changing Bag	63
Take-up Side - In Daylight	63
3.6 The GX 800 ft mag	64
Feed side, loading	64
Take-up side, loading	64
Mag ID	65
Footage	65

4 THE AATON SYSTEM

4.1 Camera Configurations	70
15mm Front Rods	70
Sliding Bridgeplate	70
4.2 Handgrip	71
Mounting the Handgrip	71
Handgrip On/Off Functions	71
Handgrip Adjustments	71
4.3 Tripod Use	72

4.4 Shoulder Operation	72
4.5 Carrying Handle	72
3/8 Accessory Screw	73
Mounting from the Carrying Handle	73
Tape Measure Stud	73
4.6 Transport	73
4.7 Extreme Conditions	74
Cold Weather	75
Warm Weather	75

5 CLEANING

5.1 Lens	80
Lens Elements	80
Lens Exterior	80
Mounting Surface	80
5.2 Body	80
Exterior	80
Mounting Surfaces	80
Camera Gate	81
5.3 Viewing System	81
Viewing Screen	82
Eyepiece	82
Viewfinder	82
5.4 Magazine	83
Exterior	83
Pressure Plates	83
Interior / Film Path	83

6 SUPER16

6.1 Super16	86
The Format	86
When to Shoot Super16	86
6.2 General Concerns	86
Protecting the Negative	86
Maintaining High Quality	87
Ordering Film	87

Film Processing	87
6.3 Shooting Super16	88
Selecting a Film Stock	88
Lenses	88
Lighting	88
Exposure	89
6.4 Super16 Field Conversions	89
Before You Begin	90
Procedure	90

7 AATONCODE

7.1 Concept	100
7.2 The Internal Clock	100
7.3 OriginCplus	101
7.4 Initializing AatonCode in the Camera	101
Using the OriginCplus - Recommended Method	102
Using an External SMPTE Device	103
7.5 Monitoring and Maintaining AatonCode	103
Monitoring AatonCode with OriginCplus	104
Maintaining AatonCode without OriginCplus	104
7.6 GMT-S	104
7.7 The Camera Assistant's Duties	105
Checking the Diodes	105
Setting the ASA	106
Checking for Running Time	106

8 TECHNICAL SPECIFICATIONS

List of Specifications	110
Connector - Pin Attributions	111
Available Viewing Screens	112

1

SYSTEM FEATURES AND CONTROLS

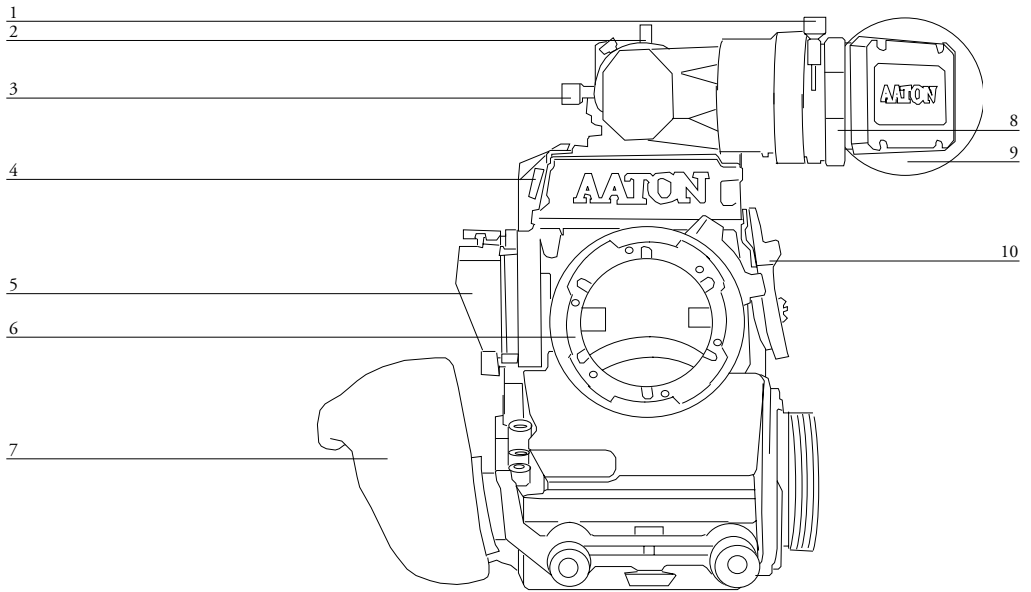

I.1 FRONT VIEW

1	Friction Adjusting Ring	<i>adjusts the tension of the eyepiece swivel.</i>
2	Tape Measure Stud	<i>holds tape measure at film plane.</i>
3	Lateral Lock Knob	<i>locks the lateral position of the viewfinder.</i>
4	Beamsplitter Access Cap	<i>covers the port which accesses the beamsplitter adjustment screw.</i>
5	CCD Cover	<i>accesses the CCD head.</i>
6	PL Lens Port	<i>standard mounting system for XTRprod.XTRprod.</i>
7	Wooden Handgrip	<i>allows for comfortable handheld operation.</i>
8	Eyepiece Lock Ring	<i>fastens interchangeable standard and extension finders.</i>
9	Eyepiece Shutter	<i>blocks light when operator's eye is away from the finder.</i>
10	Body Run/Test Switch	<i>provides camera run and half frame inching.</i>

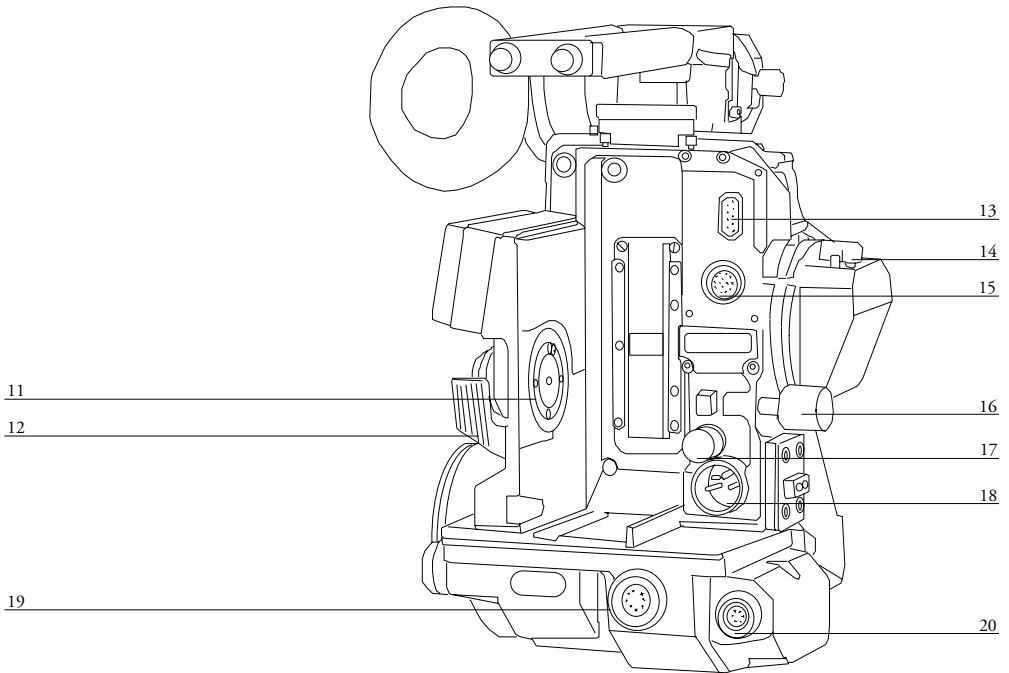

I.2 BACK VIEW

11	Magnetic Drive	<i>provides magnetic magazine coupling.</i>
12	Mag Release Lever	<i>releases the magazine for removal.</i>
13	Amph9	<i>accessory input provides +/-, Hz, and camera run functions.</i>
14	Manual Iris Lever	<i>controls CCD iris operation.</i>
15	Lemo14	<i>connects CCD head to the CCD control unit.</i>
16	Battery Lock Screw	<i>fastens the on-board battery to the camera body.</i>
17	Camera Fuse	<i>protects the body from excessive current and reverse polarity.</i>
18	XLR4	<i>main power input for on-board battery or other 12V power source.</i>
19	Lemo8	<i>accessory input provides +/-, Hz, TVsync, 100PPF and camera run.</i>
20	Lemo6	<i>accessory input provides +/- and camera run functions.</i>

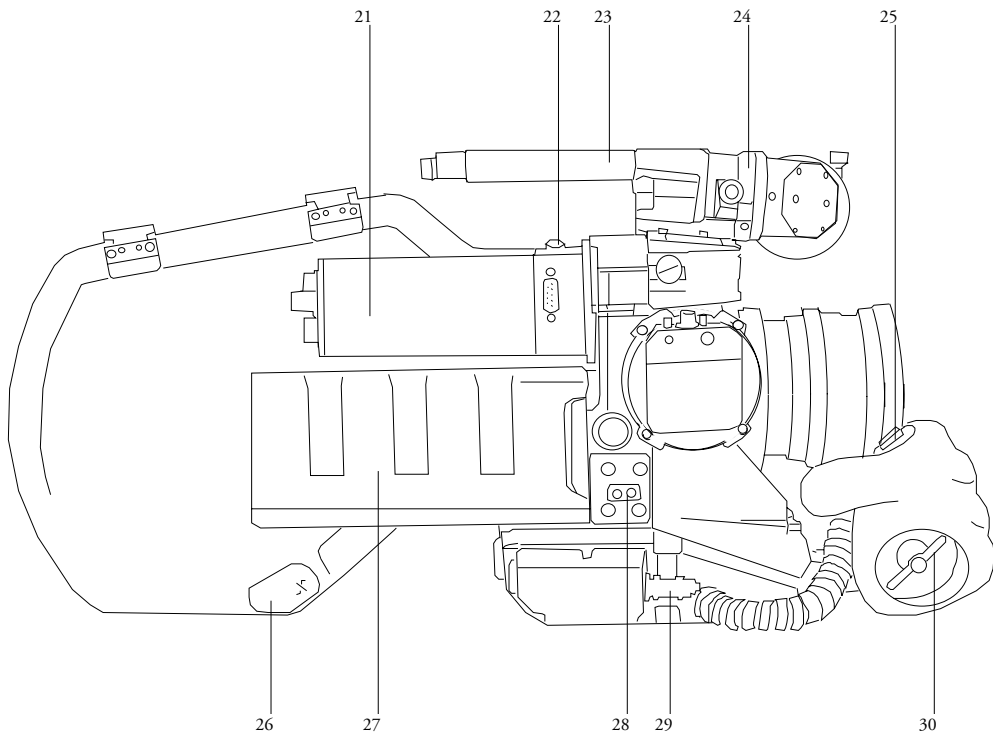

I.3 BATTERY SIDE

- 21 CCD Control Unit
- 22 CCD On/Off
- 23 Carrying handle
- 24 Diopter Set Ring
- 25 Run/Test Switch
- 26 Take-up Latch
- 27 On-board Battery
- 28 LED Indicators
- 29 Lemo2
- 30 Adjusting Screw

fastens to the body for CCD operation.

powers the CCD assist. Switch off to conserve battery life.

includes tape measure stud, 3/8-16 accessory hole and adjusting tools.

adjusts the diopter setting of the viewfinder to the operator's eye.

provides camera run and full frame inching from the handgrip.

locks the magazine take-up door.

12V nicad for handheld operation.

battery side indicators for camera run, camera test and low battery.

input provides camera run functions.

adjusts the rotation of the handgrip.

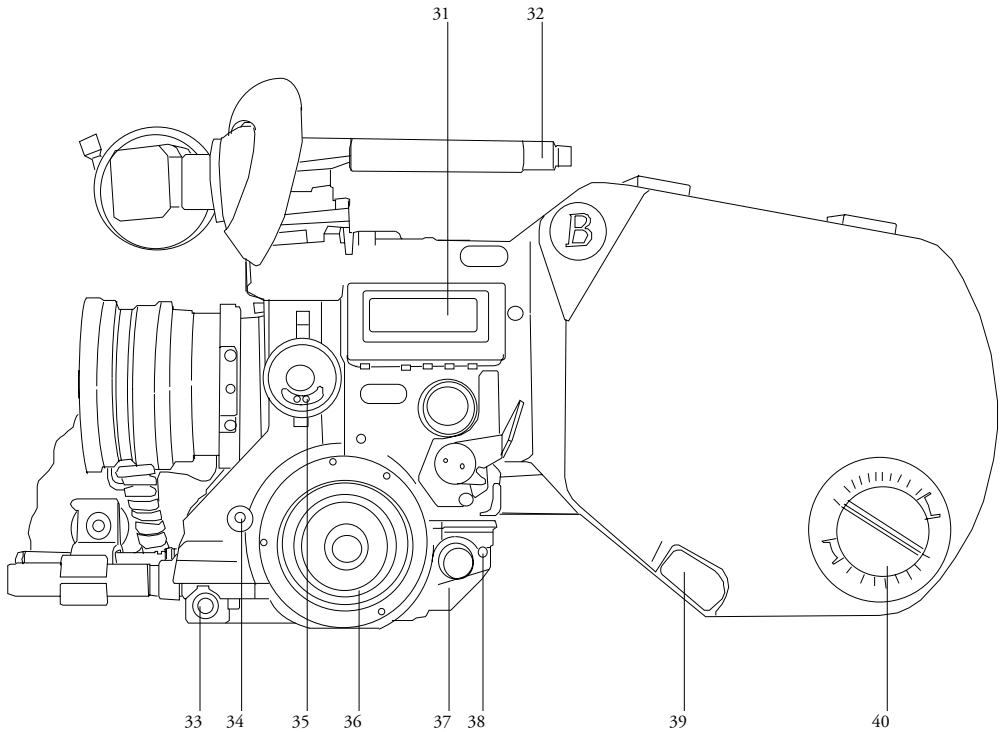

I.4 MOTOR SIDE

31	LCD Control Panel	<i>displays AatonCode, ASA, speed, voltage, remaining footage.</i>
32	Carrying Handle	<i>includes tape measure stud, 3/8-16 accessory hole and adjusting tools.</i>
33	Lemo5	<i>AatonCode and SMPTE timecode communication.</i>
34	Lightmeter On/Off	<i>activates the lightmeter display in the viewfinder.</i>
35	LED Indicators	<i>motor side indicators for camera run, camera test and low battery.</i>
36	Motor	<i>tripphase salarium, low power consumption. 3-75 fps operation.</i>
37	Aaton Jog	<i>provides quick adjustment of Aatonite, ASA, speed, phasing, footage.</i>
38	AatonCode Led	<i>flashes each second if the timecode has been initialized in the camera.</i>
39	Feed Latch	<i>locks the magazine feed door.</i>
40	Mag Footage Counter	<i>displays the footage remaining in the magazine feed side.</i>

I.5 LCD CONTROL PANEL - QUICK REFERENCE

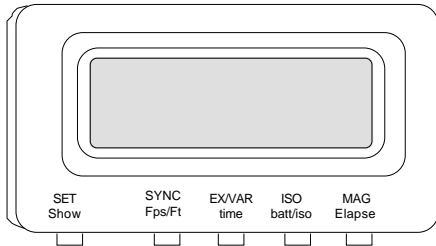

IN SHOW MODE

24' - 080	Camera speed and Remaining footage	(default mode)
ISO = 100	Film ASA	(1 x Batt/Iso)
Batt = 10'4	Battery voltage	(2 x Batt/Iso)
Ela = 042	Elapsed footage during last take	(2 x Speed)
22=32=54	Hours=minutes=seconds in AatonCode	(1 x Time)
95-03-25	Year-Month-Day in AatonCode	(2 x Time)
123456	Production ID in AatonCode	(3 x Time)
2321	Equipment number in AatonCode	(4 x Time)

IN SET MODE

Sp =2 4'	Adjusting a preset speed	(SET, 1 x SYNC, toggle SYNC or use Jog)
Sp = 27'454	Adjusting a specific speed	(SET, 1 x VAR, use Jog)
Et	Speed controled by external speed device	(SET, 2 x VAR)
Phase	Phase Adjusting	(Camera running, SET, 2 x VAR, use Jog)
ISO = 100	ASA Setting	(SET, 1 x ISO, toggle ISO or use Jog)
MAG = 400	Indicating that the new magazine is fully loaded	(SET, 2 x MAG)
MAG = 140	Indicating the new magazine's footage	(SET, 1 x MAG, use Jog)

WARNINGS

Lo Spd	Camera has not yet reached the selected speed
Lo Batt	Battery is too low (below 10V)
Empty	No more film in the magazine
Unadjust	Please check page 39
No Code	Blinking "No Code" means no timecode in the camera (press one button to remove this messabge)

2

THE CAMERA BODY



Flange focal distance

Refers to the critical distance from the lens seat to the film plane. The precise FFD of the XTRprod is 52mm -8 to -17 μ m as measured with a depth gauge in the lens port. It is recommended that these tolerances be checked and maintained by a qualified technician. The combination of FFD and back focus distance of a lens directly affects precise focus and overall image sharpness. Make sure these critical measurements are strictly upheld. When using an unfamiliar lens for the first time, check that the eye focus matches the tape-measured focus marks of the lens, and / or shoot a focus test.

2.1 LENSES

The XTRprod's flexible lens mounting system allows for the use of a wide variety of 16mm, 35mm and still-photographic lenses.

2.1.1 ArriPL Lens Port

The ArriPL lens port is the standard mounting system delivered with the XTRprod and allows the use of all 16 and 35mm ArriPL mounted motion picture lenses. PL lens adaptors are available for Arri standard and Arri bayonet mounted lenses. This mount is ideal for rental facilities, where a mounting system compatible with other manufacturer's 16 and 35mm cameras is often desired. The specific flange focal distance (FFD) of the XTRprod with PL port is 52mm -8 to -17 μ m.

2.1.2 Installing the Lens

To install the lens on the camera body, turn the outer locking ring counter-clockwise until it reaches its stop. If the port cap is on, remove it. Align the four protruding flanges on the lens with the four corresponding cutaways in the locking ring and insert the lens into the camera port so that its flanges rest evenly against the lens seat.

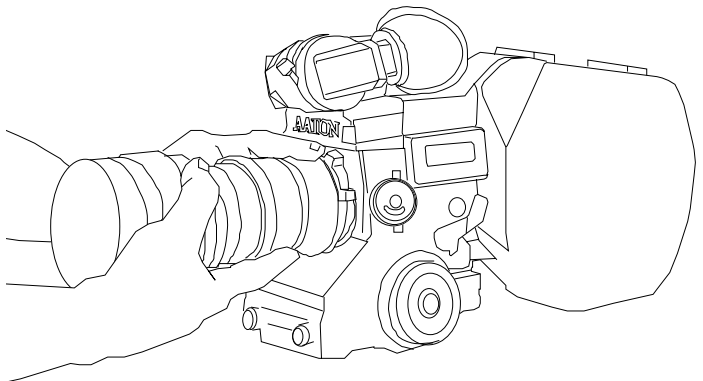

Tighten the locking ring by turning clockwise until the lens is secured in place and the lock ring is firmly set. Make sure the lock ring

is tight enough so that it cannot be inadvertently unlocked.

2.1.3 Aaton Lens Port

The XTRprod can also be equipped with an Aaton lens port. In order to install the Aaton port, the ArriPL lens seat and locking ring must first be removed.

Because the FFD of the Aaton lens port is shorter than most professional cameras (40mm), the XTRprod, equipped with this mount, can accommodate most motion picture and still camera lens mounts. Lenses can be used equipped with an Aaton mount or by adapting another manufacturer's lens mount. Aaton lens adaptors are available for Arri standard, Arri bayonet, as well as Nikon and Leica-R photographic mounts.

2.2 VIEWING SYSTEM

2.1 Viewfinder Options

The viewfinder is designed to be fully orientable, providing left or right side viewing and an upright image in any position.

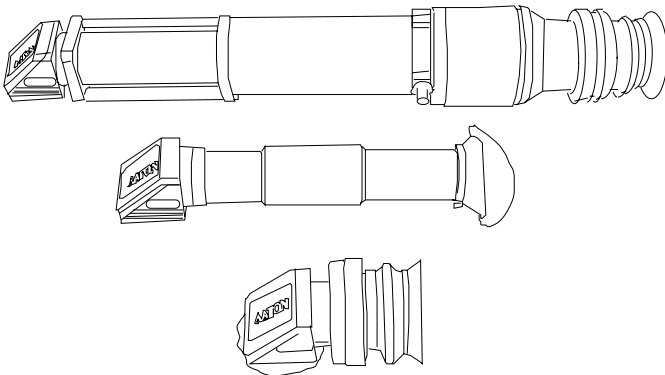

The viewfinder is equipped with a standard short eyepiece that can be used for handheld and tripod-mounted operation. For more comfortable tripod and studio applications, the standard extension finder can be fitted in place of the short eyepiece. With an Elemak or Mitchell type dolly, or in situations requiring additional reach,



The Pechan prism

In order to provide a fully orientable upright image, the Aaton viewfinder incorporates a pechan prism assembly, which is actually comprised of two triangular prisms sandwiched together. On some viewfinders, depending on the construction of this prism, rotation of the eyepiece a full 360° will cause the image in the finder to shift slightly left or right.

After attaching an extension finder, if the image in the finder appears to have shifted slightly, rotate the finder 360° and choose the preferred centered image.

the hyperlong finder can be used.

Note that standard short eyepiece can be equipped with a heating system, as well as 250mm eyepiece extension in order to avoid any condensation on the eyepiece lens. Aaton can provide you a heating lens (neutral, + 3 or - 3 diopters) and the corresponding cable.

2.2.2 Attaching the Extension Finder

In order to use an extension finder on the XTRprod, the standard eyepiece must first be removed. To remove the eyepiece, locate the eyepiece lock ring, marked A in the photo below. Rotate counter-clockwise and gently pull off the eyepiece. To install the extension finder, locate the protruding guide pin on the seat of the viewfinder and align the pin with the hole in the flange of the finder. Mate the flange to the seat of the viewfinder and tighten the lock ring until it is set firmly in place. During this procedure, you will notice that the extension finder needs to face 180° away from the operator's eye to be installed onto the viewfinder. Because of its optical construction, this is completely normal. After installation, rotate the finder 180° to regular viewing position.

2.2.3 Viewfinder Tension Adjustments

The large knurled knob at the base of the left/right lateral movement point (b) locks the lateral positioning.

The friction adjusting ring, located behind the eyepiece lock ring, can be used to adjust the tension of the eyepiece swivel, depending on the operator's preference and the viewfinder being used. When using the standard eyepiece, tension should be relatively light to allow for movement with a moderate amount of pressure. When using the standard extension finder, tension should be increased to hold the additional weight of this finder in place.

To adjust the tension of the swivel, loosen the friction adjusting ring (c). Hold the eyepiece in place, rotate the adjusting ring slightly.

To increase tension of the eyepiece swivel, rotate the adjusting ring

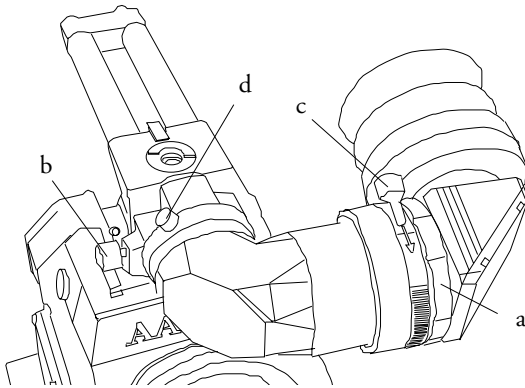

clockwise; to decrease the tension, rotate the adjusting ring counter-clockwise.

2.2.4 Adjusting the Diopter

Before shooting, the diopter setting of the viewfinder should be adjusted to the operator's eye. To set the diopter (d) look through the viewfinder, rotate the diopter set ring until the edge of the cross-hair is at its sharpest point. It is recommended that, for easiest setting, this adjustment be performed with the port cover off and no lens on the camera.

Notice that the diopter set ring is engraved with numbers and dots - use this reference to quickly recall your particular setting when more than one person will be looking through the viewfinder.

The range of the diopter setting is + or - 3. If the range does not reach your particular diopter setting, the viewfinder optics can quickly be adjusted by a qualified technician and the diopter range reset to meet your needs.

2.2.5 The Eyepiece Shutter

In order to avoid unwanted light seepage through the viewfinder, the eyepiece shutter must be closed any time the camera is running film and the operator's eye is away from the viewfinder.

To close the eyepiece shutter on the standard bellows eyepiece and 250mm extension, grasp the ring at the base of the eyecup and rota-

te 1/8 of a turn counterclockwise. On the hyperlong finder, rotate the knurled ring closest to the eyecup counter-clockwise to close the shutter.

2.2.6 Adjusting the Viewing Horizon

If the rotation of the image seen through the camera's viewfinder does not exactly match what is seen through the naked eye, there is a fine adjustment that can be made to the image's relative horizon.

Locate the small slotted screw located on the underside of the viewfinder just inside the eyepiece lock ring. Notice that the screw travels in an elongated cutout. Loosen the screw one turn and, while looking through the viewfinder, move the screw within its cutout in order to adjust the horizontal rotation. When the images seen through your left and right eyes coincide, lock the screw.



Checking your Viewing Horizon

Here is a simple means of determining whether adjustment of the horizon needs to be made. Mount a zoom lens onto the camera and rest the camera on your shoulder in a standard handheld position. Look through the viewfinder with your right eye while also keeping your left eye open. Compose a frame that includes vertical or horizontal lines (a window frame, for example) and adjust the zoom of the lens so that the focal length of the lens generally matches what you see with your left eye. Ignore the viewing screen markings for the time being and determine whether the rotation of the image you see through the viewfinder matches what you see with your left eye. If it does not, then a fine adjustment may be necessary.

2.2.7 Viewing Screen

The unique concave design of the Aaton fiber optic viewing screen gives it its superior sharpness and lucid quality. If your viewing screen possesses a dark blemish or two, don't be alarmed; these spots are actually fractured fibers and are inherent in the manufacturing of fiber screens. Such blemishes, although occasional, are the trade-off for the brilliant screens which result from the use of this technology. The XTRprod utilizes an interchangeable viewing screen system which allows the cinematographer to install the screen which best suits his particular application(s). Aaton offers ten viewing screens as standard. (see the Technical Specifications chapter) Specially marked screens can also be manufactured to order. Contact your local Aaton representative for details.

Unlike the XTRplus, which uses a universal screen that shifts between std 16 and Super16 operation, the XTRprod requires separate screens for std 16 and Super16 formats.

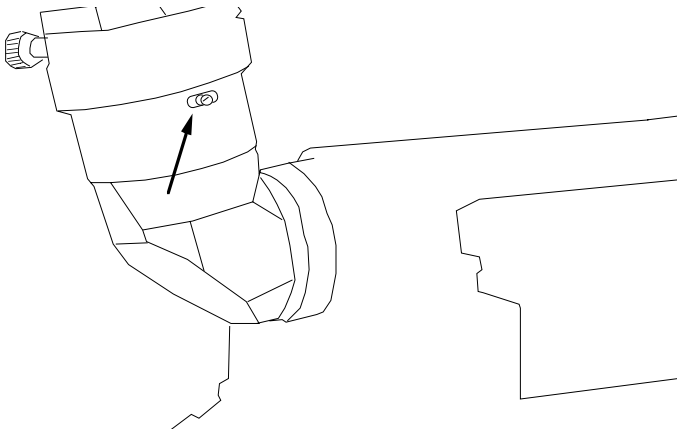

2.2.8 Changing the Viewing Screen

The viewing screen is designed to be easily removed by the user for the purposes of interchanging or for cleaning. To remove the screen, unscrew the black tool marked Vw located in the hollow at the rear of the camera's carrying handle. Remove the port cap. Clear the mirror shutter so that it is rotated safely inside the body by rotating at the base of the shutter with your finger or by setting the camera to test position, then removing the battery. Look into the port and locate the threaded hole directly above the aperture opening and screw in the tool until it is snug. Carefully pull the screen straight out.

To reinstall the screen, screw the Vw tool into the threaded hole of the screen until it is snug. Look into the port and locate the left and right lip of the viewing screen holder. With its flat side facing down, gently push the screen straight into the holder above the lip until it seats firmly in place. Unscrew the Vw tool and store back in the hollow of the carrying handle. Reaffirm that the screen is seated properly by carefully pressing against the threaded hole with your thumb.

2.2.9 Adjusting the Viewing Screen

The image on the viewing screen should be sharp, and its focus should match to that of the film. This can be best determined with the use of a collimator, or by looking through the viewfinder and

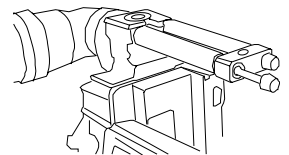

**Warning !**

Each time you're touching the mirror, the viewing screen, or anything inside the lens port, disconnect the battery. You will therefore avoid any risk of seriously damaging your camera.

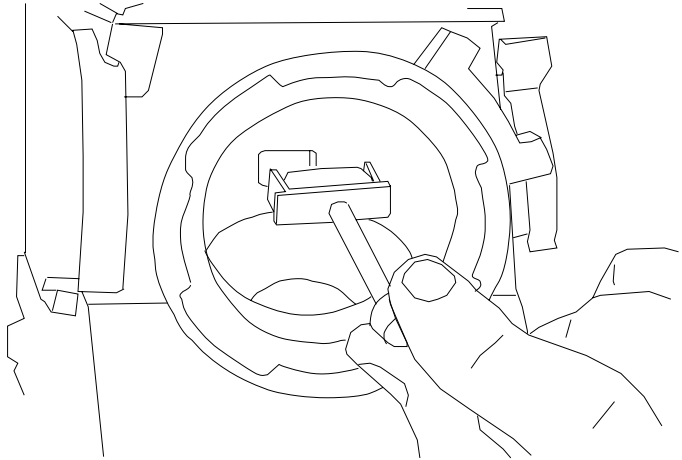

checking that the sharp focus of a lens matches the measured distance on its barrel. If it does not, then you need to make an adjustment of the viewing screen focus.

To proceed, you must first unscrew and remove the circular cap located on behind the camera body Run/Test switch. Inside the access hole, insert a 2mm Allen wrench and screw or unscrew it. Replace the circular cap. Use a collimator to check that you have reached the sharpest focus of the viewing screen image. If the image is not yet sharp enough, proceed again.

2.2.10 Aatonite Illumination

The XTRprod features illuminated viewing screen markings referred to as Aatonite. The level of illumination is adjustable by the user via the Jog wheel, which is located to the right of the motor. To operate Aatonite, power the body and switch the run/test switch to test position and off again to turn on the camera electronics. Look through the viewfinder and rotate the jog to set the desired level of illumination. The markings will remain illuminated for a full 2 minutes after the camera is set in the off position. The illumination level set in test position will be memorized and recalled once the camera is run. The illumination level can also be readjusted while the camera is

running.

The configuration of illuminated markings will differ slightly between screen types. Refer to the screen illustration on page 21 for a specific description of each screen type along with its corresponding Aatonite markings.

2.3 MIRROR SHUTTER

2.3.1 Concept

The reflex mirror shutter is designed to provide an optical path to the viewfinder while the claw movement advances the film to the next frame.

The shutter features a four-position user-adjustable opening:

- Standard 180° for filming
 - under standard 60 Hz HMI lighting at 24 fps *_or_*
 - under standard 50 Hz HMI lighting at 25 fps without flicker
- 172.8° for filming
 - at 24 fps under 50 Hz HMI lighting without flicker.
- 150° for filming
 - at 25 fps under 60 Hz HMI lighting without flicker.
- 144° for filming
 - to minimize the roll bar while filming an NTSC broadcast monitor at 24 fps.

2.3.2 Adjusting the Shutter

To adjust the shutter opening, unscrew the blue shutter tool marked Sh located in the hollow at the rear of the camera's carrying handle. Make certain that the battery is off the camera and remove the port cap. Locate the tool guiding hole to the lower right of the inside of the lens holder (see diagram). Gently rotate the shutter at its base with your finger until the brass driving gear is centered underneath the tool guiding hole. Insert the shutter tool through the guiding hole and into the brass gear. Rotate the tool until the appropriate notched shutter setting is reached; turning counterclockwise will re-

duce the shutter opening, turning clockwise will increase the opening.

When setting the opening to 172.8° or 144° , a shutter blade indicating these settings will be visible from behind the left edge of the mirror. Make sure the white line to the immediate right of the 172.8° and 144° markings meet the left edge of mirror. When the adjustment is complete, remove the tool and store back in the hollow of the carrying handle.

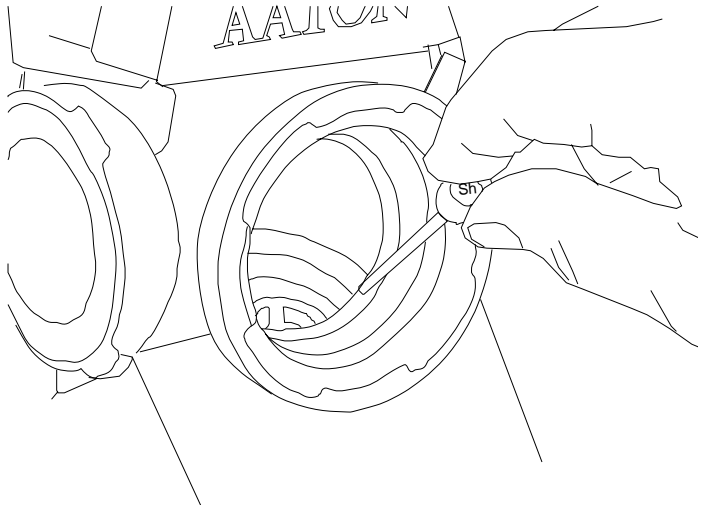

2.4 FILM GATE AND PULLDOWN CLAW

2.4.1 Co-planar Movement

All Aaton cameras incorporate a patented means of advancing the film called a co-planar claw movement. By utilizing this technique, Aaton is able to achieve an ultra-precise pulldown with a minimal number of moving parts. The co-planar concept is the key to the camera's low-noise operation.

The film gate also features a side pressure bar which is recessed into

the claw-side rail at the point of image exposure to assure maximum lateral stability.

This unique, straight forward mechanism design results in horizontal and lateral film registration that is superior to all other 16mm camera movements with an accuracy of 1/2000 of the image dimensions.

4.2 The Hair-Free Gate

In most 16mm camera designs, there is a certain amount of film dust (also referred to as fluff or hair) that is generated as film rolls through the magazine and enters the camera gate. Because the gate and pulldown are the areas where the film must be held most rigidly, these are also the areas where most of the accumulating film dust tends to be deposited. The result could be a visible hair in the picture area and an unuseable shot.

Aaton has taken steps in the design of their magazines and gate assembly to ensure hair and dust-free images. The Aaton magazine features a twistless film path with little sprocket contact, which minimizes the amount of film dust that builds up before entry into the aperture area.

4.3 Cleaning the Gate

In order to avoid film dust buildup in the recessed channels of the gate, the gate should be inspected during magazine changes and cleaned every three to four mags if the shooting schedule permits. Refer to the Cleaning chapter for more detailed information.

2.5 FLANGE FOCAL DISTANCE ADJUSTMENT

2.5.1 Concept

For a few years now, Aaton has inserted a spacer between the lens port and the camera body. This thin (0.3mm) metallic ring is responsible for the precise distance between the lens port seat and the film plane called the flange focal distance (FFD), and therefore it is

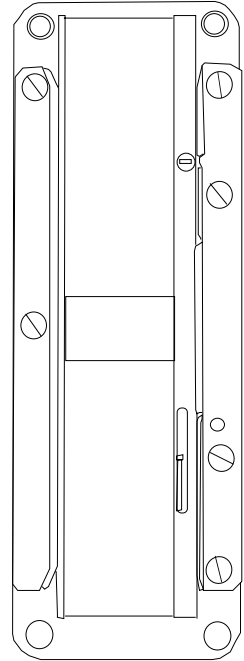

also mainly responsible for the sharpness of the images. Anyone who would like to change the FFD of his own camera should now do so by simply changing the spacer, and only with the spacer. He has not to polish any other surface, or to insert anything else between the lens port and the film plane. For that purpose, you can order some aluminium spacers (0.35mm) to Aaton, and then safely change the FFD of your camera.

2.5.2 Polishing a Spacer

In order to fine-adjust the thickness of a specific spacer, Aaton carries a specific tool (ref 09 202 92) designed to hold the spacer firmly and evenly against Emery paper. When polishing a spacer, always work on a perfectly flat worktable or stone, and be sure to hold the tool firmly.

2.5.3 Changing the Spacer

The spacer is placed between the lens port and the camera body's titanium lens holder. If your camera is equipped with a PL lens port, you first need to remove the lens locking ring: screw two or three turns its stop (placed on the bottom, inside the PL port), and turn the ring counterclockwise.

Remove the lens port by unscrewing its screws. Then remove the aluminium spacer gently.

Once you have placed a new spacer, replace the lens port, then the lenses locking ring. Do not forget to unscrew two or three turns the locking ring stop, if you have a PL lens port.

2.5.4 Adjusting the Viewing Screen

Because you have changed the distance separating the base of the lens and the camera body, the image on your viewing screen might now appear to be less sharp than usual. Most likely, you may need to readjust the precise focus of the viewing screen. Refer to the 2.2.9 section of this chapter to proceed.

2.5.5 Flange Focal Distances

Here are the flange focal distances for all the lens port available for the XTRprod.

Mont	Reference	FFD	Diametre	Adjustment
Aaton (AA)	01 112 35	40.00 mm	50.00 mm	-8 / -17 microns
Arriflex (PL)	01 113 20	52.00 mm	54.00 mm	-8 / -17 microns
Panavision (PV)	01 113 25	57.15 mm	49.50 mm	-8 / -17 microns

2.6 THE MAGAZINE

The Aaton magazine holds 400 ft (122m) of standard 16mm or Super16 film. Shooting at 24 fps, a 400 ft roll will run for 10.5 minutes; shooting 30 fps, the same roll will run for approximately 9 minutes. The coaxial design of the magazine allows for complete self-contained threading, quick mag changes and a minimal amount of loading to be performed in the changing bag. Loading the magazine is a simple operation that, with practice can be performed in a little over a minute. Refer to the Magazine chapter of this manual for complete details on loading and caring for magazines.

2.6.1 Installing the Magazine

The instant mag design allows for instantaneous switching between mags on the set. To install the magazine on the camera, situate yourself towards the rear motor side of the camera body. If the aperture cover plate is on, remove it. Place your left hand around the front of the camera just underneath the lens area. Grasp the magazine firmly with your right hand below the midway point of its rear. While holding the camera body with your left hand, guide the magazine along the base of the camera into the aperture area. Make sure that the top edge of the throat of the magazine is parallel to the carrying handle of the camera as you guide the mag in place. Push firmly and evenly until you feel and hear the magazine snap into place.

2.6.2 Removing the Magazine

To remove the magazine, situate yourself as before, towards the rear motor side of the camera. Grasp the magazine anywhere which is comfortable at its rear. Place your hand above the motor of the camera and push the mag release lever towards the front of the camera with your thumb. Pull the magazine straight off the camera with your right hand.

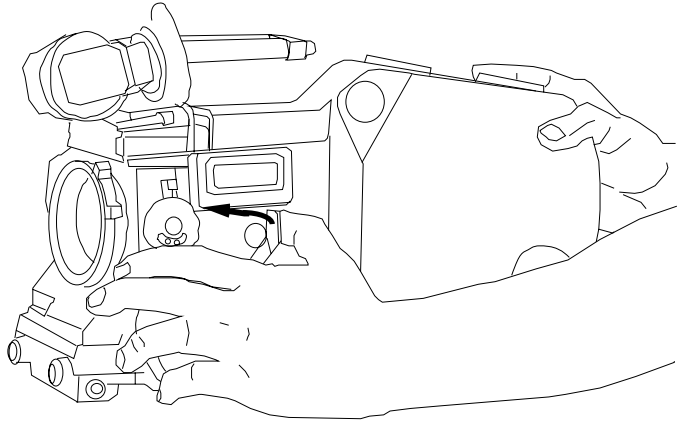

2.7 POWER

XTRprod body requires only 12 volts for all aspects of operation. One standard Aaton on-board (12V 3,2 ah rechargeable Nimh) will power the camera, CCD and any accessories which are connected to the body's accessory inputs (such as zoom controls, speed controls etc.) through a standard 4 pin XLR connector. One 3,2 ah on-board battery will run 20-22 magazines on the XTRprod, without CCD and accessories. With accessories in use, this number will decrease.

2.7.1 Installing the Battery on the Camera

The on-board battery fits below the CCD control unit on the battery side of the camera body. In order to install, loosen the black knurled screw approximately four or five turns. Push the battery evenly onto the XLR4 connection on the body. When snug, tighten the knurled screw onto the battery tab to hold it in place.

When running AatonCode, get into the practice of having a fresh battery on hand before removing the one from the camera. Even a low battery that no longer runs the body (below 10V) will have enough voltage to keep accurate time counting.

Thanks to a super capacitor built into the camera base, you will have a full minute to change the battery before time is lost. After replacing the battery, confirm that time is still counting by looking for the yellow blinking diode to the right of the motor or checking the control panel.

2.7.2 Battery Charging

The Aaton on-board can be recharged with an appropriate 12V Nimh battery charger.

For the best results, use a microprocessor-controlled charger or a standard trickle charger with a charging output of at least 200ma, both of which prevent the overheating and mistreatment of your Nimh cells. Always follow the specific guidelines of the charger manufacturer. You can use the Aaton ChA-3, designed to charge two standard batteries in 5 hours, without any risk.

Beware of older, timed chargers manufactured when 1.2 and 1.4ah batteries were the norm; these chargers were most likely rated for the lower amperage batteries of that time and will consistently undercharge the higher rated Nimh cells of today.

2.7.3 Other Power Options

Since the XTRprod power input is a standard 4pin XLR type, a great variety of 12-14 volt sources can be used to power the camera. This includes AC power supplies, battery blocks, lithium cells and car batteries.



Nimh Batteries Tips

Follow a few simple rules to insure the long life of your Nimh cells:

- Allow batteries to run through their normal cycle of charging and use. Avoid topping off partially full batteries. Once every few months, discharge cells to 8-10V using a standard discharger to minimize their memory.
- Do not rapid-charge your cells more than necessary, as the added heat will eventually shorten their life span. Instead, recharge batteries at a normal charging rate when your schedule allows.
- If your batteries will not be used for long periods of time, always store them in a cool, dry environment fully charged.

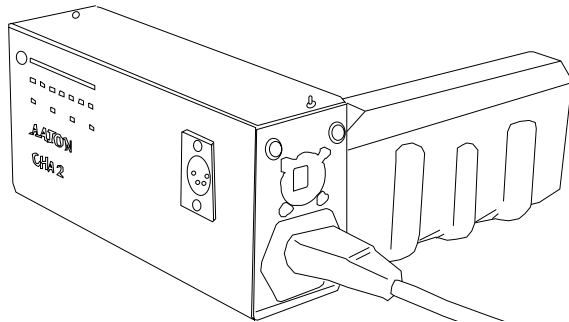

Get into the habit of carrying a standard XLR4 powercable in your package in case an alternative power source is needed.

Regarding AC power supplies, it is recommended that the unit you use be at least 4 amps and 25 watts. Before connecting any non-standard source, always make sure that the pin configuration of the unit is correct. See the Technical Specifications chapter of this manual for details for proper wiring.

2.8 MOTOR

The tri-phase samarium motor design of the XTRprod provides low power consumption and improved stability at high speeds. The body is capable of speeds between 3 and 75 fps with a standard 12V battery.

2.8.1 Camera Speeds

The XTRprod provides both preset crystal speeds (in sync mode) and specific crystal speeds (in variable mode) in .001 increments, all accessible from the LCD control panel.

Available preset speeds consist of 6, 12, 18, 20, 23.98, 24, 25, 29.97, 30, 36, 40, 48, 60 and 75 fps. The preset speed selector (SYNC) allows for quick access to these frequently used speeds.

If any other speed is desired, or if the camera speed must match the frequency of a monitor to eliminate a roll bar, the specific speed selector (EX/VAR) should be employed. The specific speed selector enables the body to run at any speed between 3 and 75 in .001 frame increments. A phase adjustment of the variable speed is acces-

sible from the EX/VAR selector.

The camera speed can also be adjusted while the camera is running in either sync or variable mode. For more information on these speed functions, refer to section LCD Control Panel and Jog of this chapter.

2.8.2 Using External Speed Devices

The XTRprod can be driven externally from devices such as film/video synchronizers, speed aperture computers and external speed controls. In these situations, the camera EX/VAR selector must be set to Et. If such a device is connected and the selector is not set to Et, the camera will run at the speed indicated on the display.

Keep in mind that, with certain manufacturer's speed controls, it may be possible to run the camera at speeds higher than the 75 fps factory limitation. Overcranking in such a way, however, will increase mechanism wear, increase noise and compromise image registration. Aaton urges to avoid such usage at all cost and will not be responsible for the resulting damage that may occur. This top speed cap of 75 fps has been designated by Aaton because it is the level at which the camera can run safely without any adverse effects on its mechanics.

2.8.3 Electronic Inching

The inching function of the motor is accomplished electronically and can be accessed in a number of ways.

- From the Body

The large run/test switch on the motor side of the body, not only runs the camera, but provides half frame inching for gate inspection, lightmeter functions and loop situating when installing a fresh mag.

- From the Handgrip

The wooden handgrip switch, by way of the Lemo2 connector, provides camera run and full frame inching for single frame operation and loop situating.

- From a Remote Cable

The Lemo2 connector, as well as Lemo6, Lemo8 and Amph9 acces-

sory connectors, provide the capability of using a remote on/off with either a half-frame or full-frame inching function.

2.9 LIGHTMETER

The XTRprod is equipped with an internal lightmeter that is designed to read the quantity of light reflected off the film itself. For added accuracy, the meter measures the light by means of two photocells. The metering system automatically compensates for filters and changes in camera speed.

2.9.1 Display

Through the viewfinder, the lightmeter display is positioned directly below the viewing screen across the bottom of the frame. A single darkened diode moves across an array of 13 yellow and green diodes, indicating proper exposure (see diagrams). Each diode represents one third of a stop, while normal exposure darkens the center green diode. Underexposure of -2 stops or more darkens the green diode on the left end of the row; overexposure of +2 stops or more darkens the green diode on the furthest right of the display.

To the immediate left of the display is the red diode indicator, which has the same functions as the red diodes on the left and right sides of the body. See section LED Indicators for further details.

2.9.2 Operation

Because the lightmeter takes its measurement as a reflection off the film, you must have film in the gate for the camera to provide an accurate reading.

To use the lightmeter, follow these simple guidelines: Set the ISO selection on the control panel to the exposure index of the film stock being used. Set the camera to run or test position and adjust the lens iris until the center green diode is darkened; this will be your proper metered exposure.

Remember, the lightmeter is giving you an average reading of the entire frame. You may choose to vary the suggested exposure according to subject conditions.

2.9.3 Using the Lightmeter without Running Film

It is also possible to use the lightmeter without actually running the camera. Set the ISO selection to the exposure index of the film being used. Set the camera to test position using the on/off switch on the body or the handgrip. If the handgrip is used, the momentary switch must be held in the test position. The mirror shutter will rotate 180° allowing light from the lens to reach the film and a reading to be taken by the meter. Adjust the lens iris until the center green diode is darkened, indicating proper exposure.

2.9.4 Testing and Adjusting the Meter

If you are operating the lightmeter for test purposes, don't forget to have film in the gate before taking a reading

The following is the procedure for checking and adjusting the sensitivity reading of the lightmeter:

- 1 - Evenly light a standard 18% grey card.
- 2 - With a loaded magazine and lens on the camera, frame the chart so that it completely fills the Super16 frame.
- 3 - With a properly calibrated handheld lightmeter, take a reading of the grey surface and set the T stop of the lens accordingly.
- 4 - Switch the camera to run or test position and check the position of the darkened diode. If the center green diode is darkened, the camera's lightmeter is set correctly. If the darkened diode is to the left or right, it is possible to adjust its reading.
- 5 - To access the lightmeter potentiometer, remove the complete



Single Frame Operation

You may use the wooden handgrip Run/Test switch of your camera to shoot a single frame: just press this button to Test and immediately release it. In that case, the film is exposed during 1/4 second.

But you need to know that the XTRprod chamber is still not opaque enough so that more than 10 minutes can separate two single image shots. To use an Aaton camera in single image shooting, you'd better use an intervalometer and a lens capping shutter.

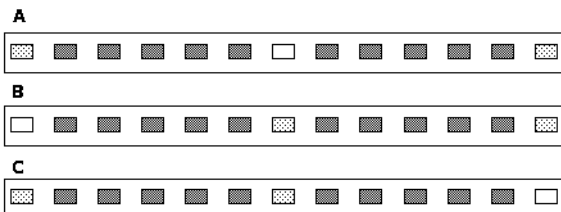

viewfinder by means of the four screws which mount it to the front housing. Locate the hole between the two viewfinder screwholes on the top motor side of the front housing. The white potentiometer will be visible within this hole.

- 6 - With a small screwdriver, adjust the potentiometer slightly; 1/8 of a turn will have an effect. Rotating clockwise will correct an overexposure and move the darkened diode to the left; rotating counterclockwise will correct an underexposure.
- 7 - In order to check your adjustment, replace the viewfinder, tighten the four screws and repeat the procedure from step 4. When the reading through the camera matches your handheld meter, the adjustment is complete.

2.9.5 Turning the Lightmeter Off

If the lightmeter is not being used, it may be turned off. The on/off toggle switch is located on the operators side to the left of the motor. Keep in mind, the red diode indicator and end-of-film warnings will function whether the display is on or off.

2.10 LCD CONTROL PANEL AND JOG

2.10.1 The Aaton Jog

Located to the immediate right of the motor, the Aaton jog is a small wheel designed to simplify many user functions. When used in conjunction with the control panel, the jog allows quick adjustment of some of the otherwise time-consuming parameters (such as the setting of a precise 5-digit speed or a film short end)

2.10.2 Understanding the Control Panel

The LCD control panel consists of an illuminated display and five buttons to access information (see diagram). The control panel operates in two modes: Show and SET. To show a parameter without adjusting, go directly to one of the four function buttons (1 through 4 in the diagram) to view relative information. To set a parameter,

first press SET, then go to the appropriate button. Information is changed by either toggling that button or by rotating the jog, depending on the parameter. Pressing SET afterwards (or waiting for 7 seconds) will enter your selection.

Capped text (SYNC, EX/VAR, ISO, MAG) refers to those functions adjustable while in the SET mode; standard text (Fps/Ft, time, batt/iso, elapse) refers to those functions accessible directly in the default Show mode.

Note that, while viewing a Show function on the control panel, any inactivity longer than 10 seconds will revert the display back to its default mode (speed and remaining footage). As mentioned previously, any break longer than 7 seconds while in SET mode will automatically enter the last selection.

The following parameters can be accessed from the LCD control panel in conjunction with the jog. For more concise information, see the table in the System Features and Controls chapter of this manual.

2.10.3 Aatonite

In its default mode, the Jog controls the level of Aatonite viewing screen illumination from zero to full brightness.

2.10.4 AatonCode

As a standard feature, the XTRprod is equipped with the capability of recording AatonCode in-camera time. Timecode information is exposed onto the film by means of seven micro-diodes, which are relayed, by means of fiber optics, into the gate above the claw to the right of the aperture opening. These micro-diodes flash rapidly to form the code as the film rolls through the gate between exposures. For more elaborate information regarding the uses and functioning of AatonCode, OriginCplus and other related devices, refer to the AatonCode chapter of this manual.

If AatonCode has been initialized in the camera, press button Time to view timecode information. Toggling button Time will display hour/minute/second, then year/month/day, then the six-digit pro-



Adjustment Tips

While adjusting the sensitivity of the lightmeter, you may wish to use your direct view of the display through the body's top cavity for reference. If so, there are a few points to remember:

- Because the image is inverted without the viewfinder in place, your adjustments will move in the opposite direction than what is seen through the finder.
- Since the cavity is open, light will enter through this opening, making any reading inaccurate by 1/3 to 2/3 of a stop. Therefore, only use the direct view of the display to reference the number of diodes adjusted. Always check your final adjustment with the viewfinder in place.

duction ID, then the camera's equipment #, in that order.

2.10.5 ASA Setting

When using the internal lightmeter and/or AatonCode in the XTR-prod, the ASA (ISO) setting must be adjusted to the exposure index of the film stock being used. The ISO selector on the LCD control panel provides settings between 25 and 1000 ASA.

With regards to the lightmeter, the setting on the ISO selector dictates to the camera what the exposure should be for a particular film stock. For AatonCode, proper ASA / ISO selection will insure that the timecode matrix recorded on the edge of the film in the gate will be exposed at an appropriate and useable level.

Press button Batt/Iso twice to view the ASA selection. To adjust the ASA setting, press SET, then button Batt/Iso. Make your selection between 25 and 1000 ISO by toggling Batt/Iso or by rotating the jog wheel.

If the ISO selector is adjusted while the camera is in test or run position, the correction will not take place until the next camera start.

2.10.6 Battery Voltage

Press button 3 to read the voltage of the camera's power source. Notice that, if the camera is running and button 3 is pressed, the control panel will read and display the voltage under load.

2.10.7 Camera Preset Speed

The default mode of the control panel will automatically display the camera speed selection, whether it be in sync or variable mode, when the camera is powered but not running. When the camera is turned on, the actual running speed to the .01 frame is displayed. To adjust the preset speed, press SET, then button SYNC. Make your selection of stepped crystal speed between 6 and 75 fps by toggling SYNC or via the jog wheel.

2.10.8 Camera Specific Speed

To choose a specific speed press SET, then EX/VAR. Make your se-

lection of any .001 incremented crystal speed between 3.000 and 75.000 fps via the jog.

To set the camera to be driven from an external source (such as film/video synchronizer or external speed control), press SET, then EX/VAR twice. Et will be displayed, indicating that camera is set in external mode.

2.10.9 Speed Phasing

The phasing of the variable speed can be set to eliminate a roll bar while filming a monitor. Operate first with no magazine on the camera, because you first need to synchronise the camera speed to the monitor frequency. Run the camera. Press SET, then EX/VAR once, turn the jog, until the roll bar seems stable on the screen. Press SET to enter. Stop the camera, and then install a magazine. Run the camera. Press SET, then EX/VAR twice. Look through the camera at the monitor and press EX/VAR until the roll bar is out of view. Press SET to enter.

2.10.10 Feet or Meters

The control panel can be set to count in either feet or meters in the following manner. Unplug power from the camera until the display goes dark. Simultaneously press button MAG while plugging power back in. Continue to hold button MAG and set camera Run/Test switch to test position; foot or meter will show on the display. Toggle button MAG to make your selection.

2.10.11 Footage Remaining

The control panel will display the memorized footage remaining any time the camera is running with a magazine on.

2.10.12 Footage Elapsed

With the camera stopped, press button MAG to view the elapsed footage of the previous camera run. With the camera running, press MAG to view the elapsed footage of that particular take. The dis-



Force Processing and the AatonCode matrix

Regardless of the situation, always set the ASA selector to the actual exposure index of the film. If you know beforehand that your footage will be pushed or pulled, don't worry about compensating for the sake of the precise exposure of your timecode matrix. The matrix is resistant enough to handle exposure variances of one and a half stops or more in either direction.



Changing Speeds while Running the Camera

Any camera speed, whether preset or specific, can be changed when the camera is running.

To do so, run the camera, then follow these simple steps:

- Operating under a preset speed (in sync mode), press SET, then SYNC, then use the jog wheel to choose a higher or lower stepped speed.

Under a specific speed (in variable speed), press SET, then VAR, then use the jog to ramp the speed higher or lower in .001 frame increments.

play will revert back to the default mode (speed and remaining footage) after 10 seconds.

2.10.13 Mag ID

The XTRprod will recall the footage according to the mag ID, which distinguishes seven magazines (A through G). To check the ID of a particular mag, as read from the control panel, press button MAG twice; the letter ID on the display should coincide with the letter on the mag's feed side door. For more information regarding Mag ID, refer to the chapter entitled The Magazine.

2.10.14 New Magazine's Footage

With a fully loaded magazine on board, press SET, then button MAG twice to reset the control panel to count down a full 400 ft load. If a short end is being used, press SET, then button MAG, then reset the desired footage via the jog.

Note that the camera does not take a physical reading of the film roll to determine the footage reading on its display; it is only a counter and it must be set by the user. There is, however, a mechanical footage counter on the magazine that automatically measures the size of the camera roll; use the magazine footage counter to determine the correct short end length to input on the control panel.

2.10.15 Camera Software Version Number

If you need to know the software version number your camera is equipped with, proceed as follows. Unplug the battery from the camera. Put the camera on Test mode. Then, while plugging back the battery, watch carefully the LCD control panel. During one second it will display the camera software version number.

2.11 LED INDICATORS

The XTRprod utilizes LED indicators in three locations to convey information: in the viewfinder and on both left and right outsides of the camera body.

2.11.1 Position and Meaning of the Diodes

- Two yellow diodes, placed on both right and left sides of the camera body indicate that the camera is either on Test or on Run mode.
- Two red diodes, placed on both right and left side of the camera body, and a third one, visible from the viewfinder, display a special warning.
- One yellow diode, located to the right of the Jog wheel and called the timecode diode, flashes each second if the timecode has been initialized in the camera.

2.11.2 Camera Test Indicator

l Yellow diode is on.

l m l m l Red diode is blinking fast.

2.11.3 Camera Run Indicator

l Yellow diode is on.

m Red diode is off.

2.11.4 Low Battery Indicator

l Yellow diode is on.

l m m l m m l Red diode is flashing slowly.

The LCD control panel displays Lo Batt.

2.11.5 Low Speed Indicator

l Yellow diode is on.

l m l m l Red diode is blinking fast.

The LCD control panel displays Lo Speed.



Displaying a 5 Digit Speed

If the XTRprod is set to a variable (5-digit) speed, the control panel will only display that speed to the .01 digit. Keep in mind, the display will not round off the speed, but simply leave off the last digit. For example, if the 5 digit speed of 23.976 is entered, the control panel will display 23.97, not 23.98.



Remember...

Variable Speed for Phasing

Keep in mind, the speed phase function of the control panel will only operate when a variable speed is initially selected.

When shooting 29.97, for example, be sure to choose the specific 29.970 instead of the preset 29.97 if you plan to incorporate the phase function for that particular shot.

2.11.6 End-of-Film Warning Sequence

The lightmeter display features pre-end-of-film and end-of-film warnings for the operator.

Under normal operation, the lightmeter display will flash once for every foot or meter that is counted down. When the footage counter on the LCD control panel counts down to 10 feet remaining, the display will flash more rapidly, at a frequency of about 2-3 times per second. Keep in mind, the pre-end-of-film warning will only operate if the lightmeter display is turned on.

When the counter reaches zero, the left and right sides of the display will alternately flash, indicating the end of a roll. The end-of-film warning will function whether the lightmeter display is on or off.

2.11.7 8-hours Warning Sequence

The timecode diode flashes slowly, every 4 seconds, to indicate that 8 hours have now been elapsed since the timecode was initialized or controlled in the camera. You need here to re-initialize or to control your camera timecode.

2.12 CCD ASSIST

The Aaton VSA (Video Synch Assist) color CCD tap is designed to add video assist capability to the XTRprod without compromising the body's size, flexibility and ease-of-use. Because the CCD head is incorporated into the XTRprod camera body, there are no centering or focus adjustments necessary (unless, of course, when converting the body between 16 and Super16 formats). The control units for all Aaton CCD assists attach quickly to the camera's PBX housing and can be used with an on-board battery.

2.12.1 Installing the Control Unit

The VSA control unit can be easily attached onto the XTRprod in a few seconds without the need for adjustment.

Remove the two allen screws located on the PBX immediately below the Lemo14 connector. Mate the Amph9 and Lemo14 connectors

of the control unit to those connectors on the body and plug in the unit.

Replace the two allen screws to fasten the control unit; a third screw of the same size should be screwed into the upper right side of the unit from the opposite direction.

The control unit can remain permanently attached to the XTRprod without adding discernable bulk or weight. Simply keep the unit turned off and the beamsplitter retracted (see below) when video assist is not needed.

2.12.2 The Internal Beamsplitter

The Aaton CCD assist system employs an internal, user-retractable beamsplitter that reroutes a portion of the viewfinder's light path to the CCD target while the video assist is in use. In situations which do not require the CCD assist, the beamsplitter is designed to be retracted to allow 100% of the viewfinder's light to reach the eyepiece. From body # 1928 and on, the beamsplitter delivered as standard from the factory has a 75/25 reflection ratio. This means that 25% of the light from the viewfinder is sent to the CCD target when the beamsplitter is in place. Although not visible from the outside of the body, the 75/25 beamsplitter is identified by its blue anodized holder.

Also available is a 50/50 beamsplitter, which sends a greater percentage of light to the CCD target.

2.12.3 Positioning the Beamsplitter

The beamsplitter adjustment screw is located underneath a small, capped port on the battery side of the camera. To access the beamsplitter, unscrew and remove this silver cap. An allen head adjustment screw will be visible through the opening. With the shutter tool, gently rotate the adjustment screw approximately 30 turns in the desired direction to position or retract the beamsplitter.

After 30 or so turns, the adjusting screw will reach its stop and resistance will be felt. At this point, stop and rotate the adjusting screw

one turn in the opposite direction to complete the adjustment. By backing the beamsplitter off its stop, fine centering of the CCD target is maintained and the beamsplitter itself is less susceptible to residual shocks caused by a drop or sudden jolt.

Positioning the beamsplitter for video use - the adjusting screw should be rotated counter-clockwise to move the glass in place.

Retracting the beamsplitter for non-video use - the adjusting screw should be rotated clockwise to move the glass out of viewing area.

2.12.4 The Beamsplitter Axis Adjustment

The beamsplitter axis adjustment is used to recenter the CCD assist image when switching between 16 and Super16 formats. If, when you turn on the control unit, the image on your monitor appears off to one side, the angle of the beamsplitter must be adjusted.

The beamsplitter axis adjustment is located to the above/right of the aperture and consists of an allen screw within a slot (see diagram on the following page). A red dot to the upper left of the slot indicates the position of the screw for Super16.

Loosen the allen screw one turn; while looking at the monitor move the screw within the slot in the appropriate direction until the image of the screen is centered. Afterwards, if the image is not sharp, follow the directions under 2.12.17 Installing the CCD Head to adjust focus.

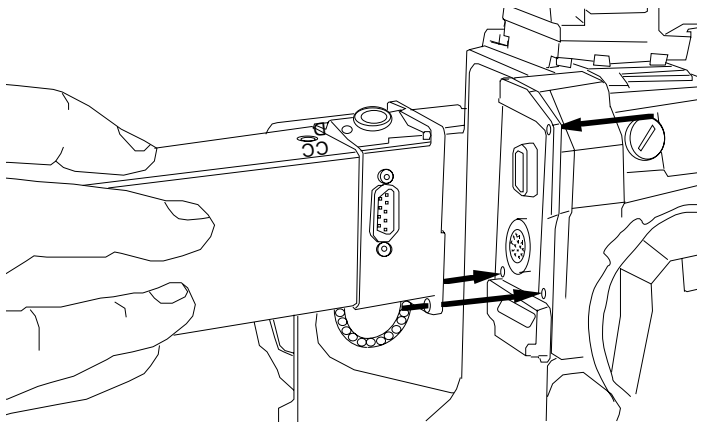

2.12.5 The Manual Iris

The VAS assist features an automatic gain. In certain situations, however, further light control may be desired (such as high contrast or strong back-light circumstances). In these instances, it is recommended to employ the manual iris feature, which is located on the CCD head cover on the battery side of the camera.

Under normal operation, this mechanical iris should be wide open. When further light control is necessary, look at the video monitor and move the iris lever to the left to the desired degree.

2.12.6 Battery Life with CCD Assists

The VSA assist draws, because of its color, frame-store and timecode capabilities, 750ma when powered. This translates into approximately 3 to 4 hours of operation (without the XTRprod running) from one 12V 3,2 ah on-board battery. For this reason, it is recommended to use a battery block or AC power supply when using the VSA for long periods of time.

Although battery life will vary greatly depending on the amount of film run and the number of accessories powered from one power source, you could estimate that one 12V on-board could run 10 magazines and the VSA for 2-3 hours.

In order to conserve battery life, get into the habit of shutting off the VSA assist when not in use.

2.12.7 Installing the CCD Head

Under normal circumstances, if you own a video assist, you will not need to deal with the removal and/or installation of the CCD head. The head and its accompanying relay lens are designed to remain within the camera body whether the assist is being used or not.

In some instances, however, such as the renting or sharing of a unit among a few cameras, it would be necessary to remove and install this head.

The installation and removal of the VSA color head assembly is somewhat involved and considered a shop operation. Therefore, it is recommended that this procedure be performed by a qualified technician. If you own a VSA, however, and feel that you would need to remove the assembly frequently, this procedure can be demonstrated and taught to you by an Aaton technician. Contact your Aaton representative for further details.

- 1 - Unscrew the four allen screws as indicated in the diagram below and remove the PBX cover plate and rubber gasket. On the cover plate, you'll notice a plastic plug which is press-fit into the cover plate. Remove this plug by pushing it to the inside of the plate. If it is very tight, use a pencil eraser to do the job. On some cameras, you may find a blank cover plate without a hole. If this is the case, remove this plate completely and use the plate supplied with the CCD assist in its place.

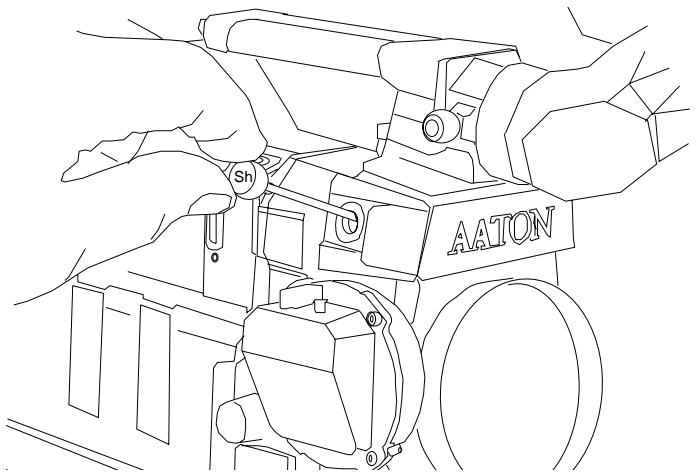

- 2 - Remove the four screws which hold the CCD cover onto the battery side of the camera and carefully remove the CCD cover.
- 3 - Check that the exposed lens of the CCD head assembly is free of dust particles. If necessary, clean this surface with lens fluid applied with a foam or cotton Q-tip. In order to install the head assembly into the side cavity, first feed the Lemo14 connector into the PBX so that it faces towards the rear of the camera. With the iris rod facing up, install the head assembly into the tubular holder until the steel collar is stopped by the tube.
- 4 - While holding the head assembly in place, locate the allen screw in the diagram above and tighten moderately until the head assembly is secure. To avoid any damage to the relay lens housing, do not overtighten this screw.
- 5 - Position the Lemo14 in its cutout within the PBX and hold in place. Make sure that the flat index towards the rear of the connector faces up and mates with the flat in the cutout. Do not confuse

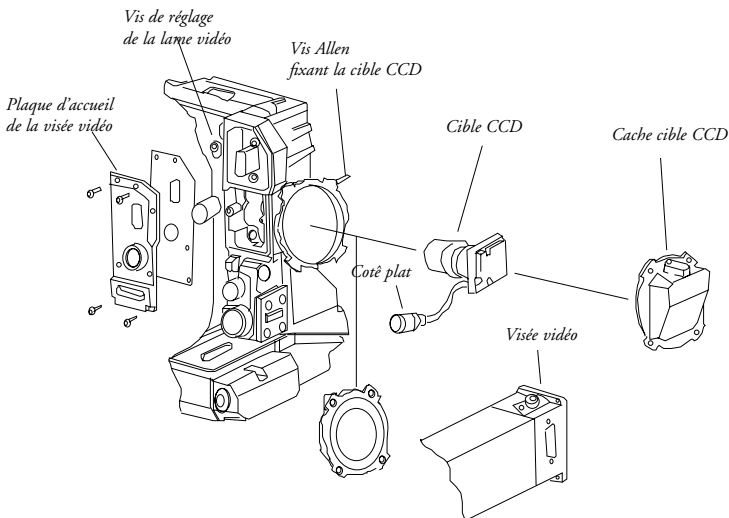
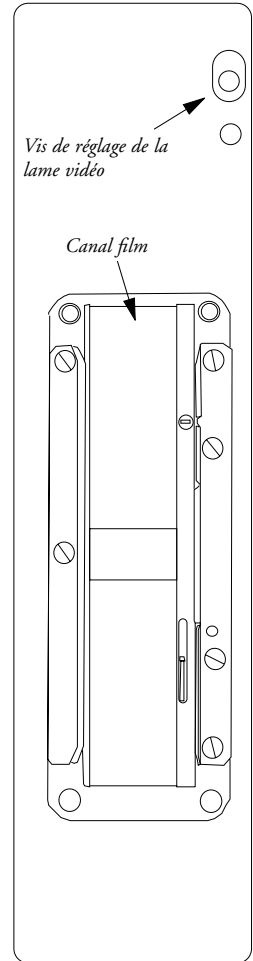

this flat with the two flats on the threaded portion of the Lemo.

- 6 - Replace the rubber gasket and the PBX cover plate via the four allen screws. Double-check that the Lemo14 sits flush against the lip of the circular opening in the cover plate.
- 7 - Plug the control unit into the PBX and fasten it to the body with three allen screws. Connect a BNC cable to a monitor and power the XTRprod. Turn on the toggle switch of the CCD assist; the yellow diode should light. You should also see an image of the viewing screen on the monitor. If this is not the case, the beamsplitter may be retracted. Remove the beamsplitter access cap on the battery side of the camera and position the beamsplitter by rotating the adjustment screw approximately 30 turns counter-clockwise until it reaches its stop. Back off the stop one turn clockwise.
- 8 - Locate two allen head screws on the CCD head identified by a red dot (marked A above). Loosen the screws 1/2 a turn. While loo-

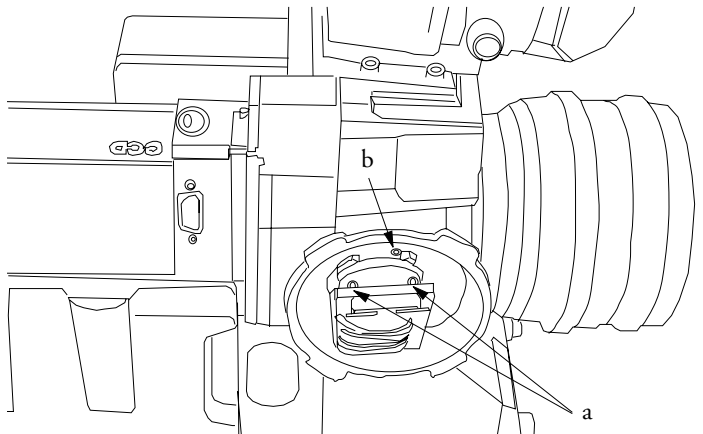

king at the monitor, gently move the CCD head until the viewing screen image is in focus. Notice that this adjustment also affects image rotation. When sharp, even focus is achieved and the image is square to the monitor, tighten the two screws.

- 9 - If the CCD image is centered in the monitor, your adjustment is complete. However, if the image is off to one side, the beamsplitter axis adjustment needs to be reset. Follow the directions under 14.4 The Beamsplitter Axis Adjustment to recenter the image. Afterwards, loosen the two screws on the CCD head and refocus the optics.
- 10 - Locate the iris rod on the CCD head (marked B in diagram) and move it by hand to an upright position. Replace the CCD cover on the body; take care to locate the iris control fork and position it around the iris lever. Tighten the four screws to secure the cover in place. Operate the manual iris lever and check that the CCD iris itself is functioning by looking at the monitor. If the brightness of the image does not change, the iris rod may not be engaged in the control fork. If this is the case, remove the CCD cover and repeat the procedure.

2.12.8 The VSA Color CCD Assist capabilities

You may use the VSA color CCD assist in two different ways.

In some special situations (if you're filming in the dark for example), it might be more comfortable to look your images on a monitor than through the viewfinder. This is why the VSA is equipped with a frame generator: as you can choose the size and position of the generated frame, the image you see through the viewfinder (which might be in ratio 1.78 or 1.66 for example) can match exactly the image you see inside the frame on the monitor. Moreover this frame is easier to locate than the viewing screen's frame. The director can then immediately control his operator's images, or the operator is allowed to stay away from his camera.

Of course, the video assist was first created to be used in such a way. But, now that video editing (including the virtual video editing) offers new powerful tools to the editor, the VSA can be used in a different way. The VSA provides a Vitc lines generator, which are the dots and lines, usually put above the video image, used by video editing machines. Therefore, images recorded by the video assist may be directly used to make a video editing of the film; no need to use

a telecine, no need also to have developed the rushes you won't use.

2.12.9 Menu Operation (V5.00)

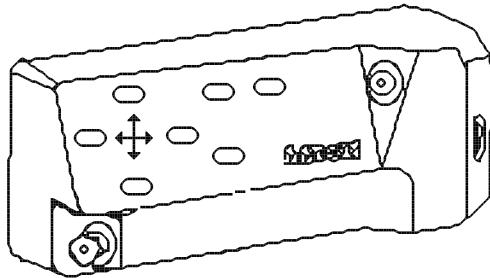

The control unit contains seven operator buttons: up, down, left, right arrows, menu on and exit keys.

- Press **On** to switch on the video assist
- Press **menu** to have the menu displayed.
- Use **arrows** to access to the desired parameter.
- Press **menu** to indicate that you want to modify this parameter.
- Use **arrows** to adjust this parameter.
- Press **menu** to validate
- Press **exit** to memorize the new configuration.
- Press **On** during 3 seconds to switch Off the video

SET VIDEO

- The **Output** function allow you to choose between color and black/white.

- **Color temperature** - Depending on which kind of emulsion you are using. In order to have the video colors closer to the film colors, you can choose between 3200K, 5600K.

- **Gain** - The Gain function (manual) increases visibility in low light situations, but increases video noise. The medium setting is **000**,

you can increase or decrease the gain from -155 to + 100 Use arrows to proceed.

DATE

- **Date** allows you to choose the position of the current date insertion inside the video image. Use arrows to proceed.

TIME

- **Time** allows you to choose the position of the current time insertion inside the video image. Use arrows to proceed.

CAM

- **Cam** allows you to choose the position of the current cam insertion inside the video image. Use arrows to proceed.

FRAME

- **Frame On/Off** allows you to choose if you want or not a frame to be inserted in the video image.

- **Frame 1,2,3 or 4**, allows you to memorize 4 different frames. The 4 frames can not be inserted at the same time.

- **Frame Top Left** allows you to choose the top-left position of the frame. Use arrows to proceed.

- **Frame Bottom Right** allows you to choose the bottom-right position of the frame. Use arrows to proceed.

- **Frame move** allows you to move the complete frame in the picture. Use arrows to proceed.

- **Edge Shadow** allows you to choose between a white or black edge around the frame or no edge. Use arrows to proceed.



Vitc lines

- First line is the video timecode line. Each time you switch on the video assist, the video timecode is set to 1:00'00" 00 (the last number is the image number). The time count is continuous regardless of the camera.
- Second line is the keycode line. As the keycode should be read from the film, this line cannot be generated. Only synchronization and checksum bits are inserted.
- Third line is the audio timecode line, i.e. all the timecode information of the AatonCode are inserted here.

TECHNICAL

- **Time Code Off/On** allows you to choose to insert (On) or not (Off) AatonCode information, which consists of Time, Date and Equipment number ID.

- **Font** allows you to choose the font you need for the characters to be inserted. Choose 1 for standard characters and 2 for bold characters.

- **Automatic Power Off** allows you to choose between an automatic shut off (On) or a manual one (Off).

- **Delay to power off** allows you (displayed only if the Automatic Power Off mode has been chosen) to choose an automatic shut off of the video assist, from 10 to 60 minutes. Use arrows to proceed.

- **Vitc Position** allows you to choose the position of the Vitc lines. Choose between line 10 and 19 in PAL (Aaton recommends line 19), between 13 and 19 in NTSC.

- **Parity** allows you to select the parity of the Vitc lines between Odd and Even.
Make sure that your Post-production tools run properly with the selected value.

- **Low camera Speed** allows you to increase brightness and sharpness in low camera speed mode (from 3 to 12 fps).

- **Burn-in White level** allows you to modify the intensity of the white burn-in frame. You can choose from -100 (almost grey) to +50. The medium position is 000. Use arrows to proceed.

3

THE MAGAZINE

3.1 CONCEPT

The Aaton DX Magazine incorporates many features which add to the camera system's ease-of-use, efficiency and reliability. The magazine's coaxial design allows for separate feed and take-up chambers, which ensures that the bulk of the loading process is performed in daylight.

The DX Magazine is driven magnetically from an intermediate drive connected to the camera motor; a magnetic wheel on the inner side of the camera body couples with a similar wheel on the throat of the magazine to transport the film. This magnetic drive system decreases noise and power consumption, and prevents mechanical stress during mis-loads.

The magazine handles up to 400 ft (122m) loads of double or single perforated 16mm film stock. 400 feet of film is approximately 10.5 running minutes at 24 fps.

3.2 COMPATIBILITY

3.2.1 DX Magazines

Since the introduction of the XTR in 1984, only DX magazines have been manufactured by Aaton, all of which can be used on today's XTRprod (approximate ser #3500 and above). The DX code distinguishes this magazine from earlier designs. D refers to its emulsion-out Super16-safe coaxial roller (further explained below). X refers to its magnetic drive system.

3.2.2 Super16 Safe

All DX magazines are designed to safely transport either standard or Super16 stock. Capped rollers keep the running film from riding up and prevent any contact within the picture area. The mag's large coaxial roller, which transports the film from the feed into the take-up chamber, handles the film on its less-sensitive base side and facilitates a long and twistless film path. (Severe twisting of the more sen-

sitive high speed stocks, as is the case with the LTR and some other manufacturers' magazines, has been known to cause grain fracturing and a resulting abnormal exposure of the film in that area.)

3.3 PRESSURE PLATE SYSTEM

The DX magazine features two pressure plates which are located at the front of the nose of the magazine. When the loaded magazine is attached to the camera, these pressure plates provide the precise stabilization of the film during exposure and transport.

3.3.1 The Picture Plate

The upper four-striped pressure plate, called the picture plate, is positioned at the camera's aperture opening and is designed to hold the film steady at the point of exposure. Proper setting and functioning of the picture plate assures the precise focus of each image.

3.3.2 The Claw Plate

The lower plate, called the claw plate, is positioned at the pulldown

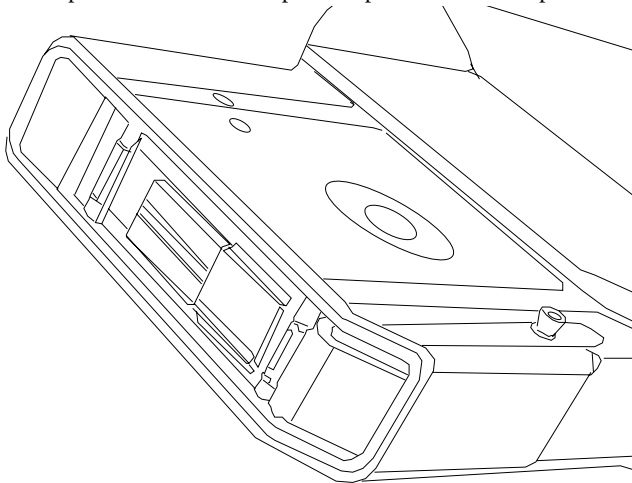



ID of Mags on XTRplus vs XTRprod

As mentioned, the XTRprod can distinguish seven magazines because its sensors can read all three receivers. The XTRplus, however, can only distinguish three magazines, as its sensors will only detect the two upper receivers. Be aware of this fact when renting additional magazines. For example, a mag which is read as a G on an XTRprod will be read as a C on an XTRplus camera; as the lower receiver will not be detected.

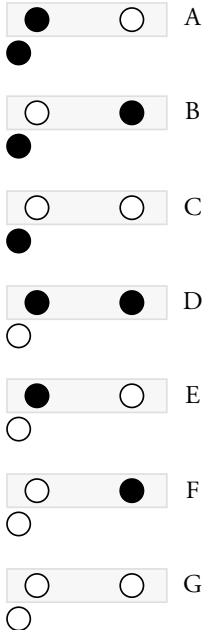

claw and functions to stabilize the film as the claw engages the film perf between exposures. Proper tension and functioning of the claw plate contribute to reliable transport and quiet operation.

3.4 MAG IDENTIFICATION SYSTEM

3.4.1 Mag ID

Each DX magazine bears its own identification (ID) determined by the combination of magnets in receivers located above the drive wheel on the throat of the mag. This identification is used by the camera to recall the remaining footage of a mag removed from the body unfinished. The XTRprod can differentiate seven magazines (A through G) via electronic sensors located within the LCD control panel and recall the memorized footage for each. By comparison, the less sophisticated display of the XTRplus can identify only three magazines (A, B, C).

The chart to the right represents the seven IDs which can be read by the XTRplus and XTRprod cameras, with the corresponding magnet in receiver combination for each.

3.4.2 Changing the ID of a Magazine

The Mag ID of a particular magazine can be easily changed by the user. Determine the magnetic receiver(s) that need to be changed according to the chart above. Locate the small silver spanner tool located on the coaxial roller in the feed side of the mag. Using this tool, loosen and remove these receiver(s). A spare receiver is located at the base of the coaxial roller. Install the appropriate receivers as necessary. Remember to change the letter decal on the outside of the feed side door to match the new ID. For spare decals, contact your Aaton representative.

3.5 LOADING

- magnet
- no magnet

The straightforward design of the DX magazine allows for quick, easy loading and an absolute minimum amount of threading in the dark. The film does not need to be cut in preparation for loading.



3.5.1 Feed Side - In the Changing Bag

- Place the film can and the magazine, feed side up, in the changing bag and zip closed.
- Disable the mechanical footage counter, located on the feed door, by rotating counter clockwise until it locks in its recessed position.
- Unfasten the feed door lock by turning downward and open the feed door.
- Remove the film from its can and bag.
- On the feed core holder, squeeze the core lock mechanism on either side with thumb and forefinger to release core lock.
- Place the film on the feed spindle with its wind clockwise and press the center of the core lock to lock the core in place.
- Thread 4" of film around the outside of the lower guide roller and through large coaxial roller emulsion out. Make sure that the length of film feeds completely through to the take-up side.
- Close and lock the feed door and engage the footage counter by rotating clockwise.

Care for your Changing Bag

A clean and light-tight changing bag is the only thing separating your precious footage from a veritable washout. Before using your changing bag each day, turn it inside out and shake it clean of dirt and debris. It is also a good practice to periodically inspect its edges for holes and tears. Hold it up to a strong light to check for any pin hole leaks.

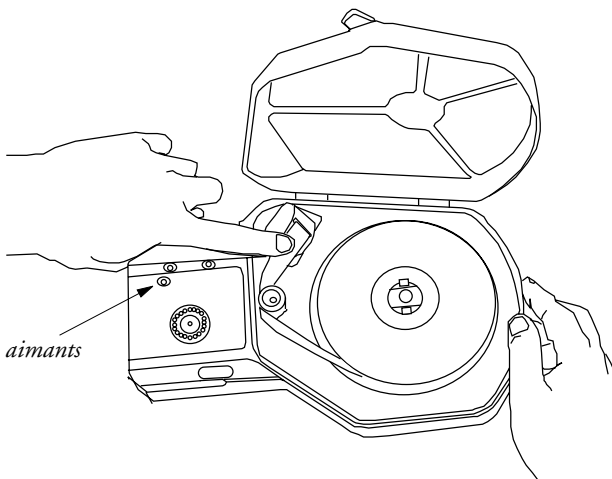

-
- Remove the magazine from the changing bag.

3.5.2 Take-up Side - In Daylight

- Unfasten the take-up door lock by rotating downward and open the door.
- Release the doors of the upper and lower pinch rollers by pressing the white buttons and gently pulling open.
- Pull the length of film from the slot of the coaxial roller and pass

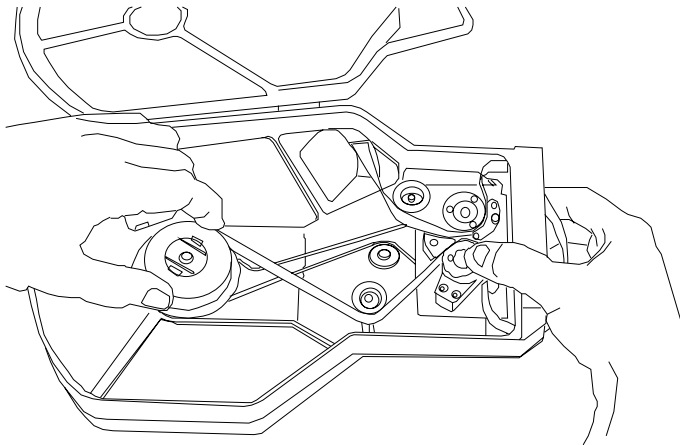

below the first idler roller. Bypass the upper sprocket for the time being and push the film directly through the upper channel slot to the outside of the nose. Pull through about one foot in length.

- Reintroduce the film into the lower slot, back into the magazine.
- Place a plastic take-up core onto the take-up spindle, check that the core is seated properly, and press the center of the core lock to lock the core in place.
- Bypass the lower sprocket for now and pass the film underneath the lower roller. Fit the film end into a plastic take-up core and wind on a few turns counter-clockwise and emulsion in.
- Thread the film around the lower sprocket, making sure the film's perforations engage the sprocket teeth. Close the lower pinch roller until it locks firmly in position and a noticeable click is heard.

- Hold the lower sprocket with your right thumb and rotate the take-up core counter-clockwise to remove any slack.
 - Thread the film around the upper sprocket and adjust the loop until its taut length is 14 to 15 frames long outside of the nose.
- When the proper length is achieved, close the upper pinch roller until it locks firmly in position.
- Remove any slack, then close and lock the take-up door.



The Two-Finger Rule

When loading the take-up side of the magazine, the loop size can quickly be measured by inserting two fingers within the loop perpendicular to the mag's pressure plates.

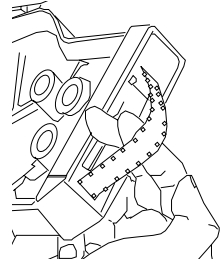

At first, determine proper loop size by pulling the looped film away from the mag, counting and adjusting for 15 to 16 visible perforations for a length 14 to 15 frames long. Then, insert two fingers and check how the spacing relates to the proper loop length. Of course, each person's finger-measured equivalent will be slightly different, but for most people, a tight two-finger length is approximately a 14 frame loop, a loose two-finger is about 15 frames. After you become familiar loading the mag, you should be able to use the two-finger method to save time setting your loop.

3.6 800 ft magazine

Though the 800 ft design and loading is very close to the 400 ft magazine, the following points need to be respected.



Warning :
Never use the 800 ft magazine without both platters.

3.6.1 Feed side, loading.

The loading is very similar to the 400 ft. Do not forget to install the upper platter when the film stock is loaded. This platter allows the proper driving of the film, reduces the noise level and avoids scratch problems. This platter and the take-up side platter must always be clean.

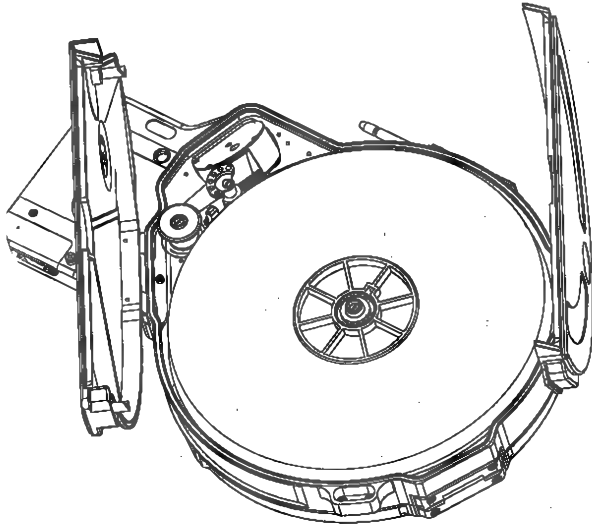

3.6.2 Take-up side, loading.

The film path is the same as the 400 ft magazine. The 800 ft film stock is delivered with a 3 inch core. It is necessary to use this kind of core to ensure a proper take-up. If you need these cores you can ask your Kodak dealer. The 2 inch core can be used but Aaton advises against it. The loop has to be adjusted to 14-15 perfs. Do not forget to install the take-up side platter.

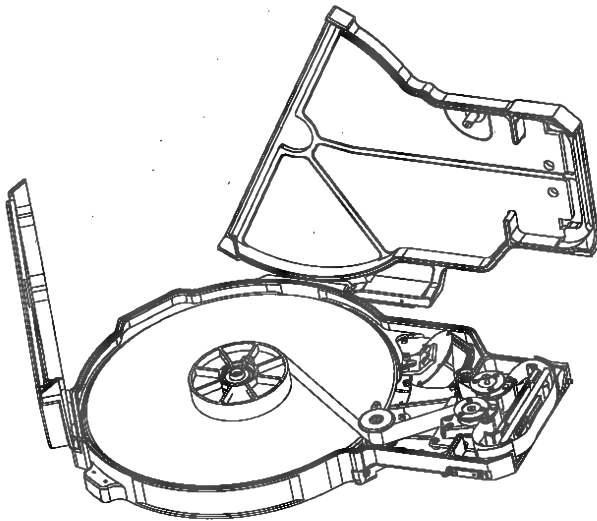

Warning : when you install the platter, be sure that the edge of the platter is placed on top of the driving roller. An incorrect positioning could create some take-up problems.

- **Mag identification system**

Determined by the combination of magnets in receivers located above the drive wheel on the mag throat (same combinations than the 400 ft magazine).

- **Footage**

A sensor coupled to an external display, allows to verify the remain footage in the magazine.

The XP 5.13 software (installed on XTRprod cameras from serial number C 2127) allows to adjust the LCD display of the camera on 800 ft. With the earlier XTRprod, you must install this new software (delivered with the magazine).



Note : with XTR and XTRplus cameras, the LCD display does not indicate the remaining footage in the 800 ft magazine. This function is strictly reserved to the XTRprod.

THE AATON SYSTEM

4

4.1 CAMERA CONFIGURATIONS

4.1.1 15mm Front Rods

The most versatile and popular configuration for accessorizing the XTRplus camera, the universal 15mm screw-in front rod system can instantly accept Aaton, Arri, Chrosziel, Petroff and other manufacturers' mattebox and follow focus systems. Utilizing the front rod system allows for quick conversion from tripod to shoulder operating modes without the need for reconfiguration.

Aaton manufactures 60mm and 120mm length rods that screw directly into the front housing of XTRprod underneath the lens port. The 15mm front rod system is recommended when standard size lenses and accessories are to be used or when quick conversion between tripod and handheld modes is necessary.

4.1.2 Sliding Bridgeplate

The XTRprod can also accept standard 15 and 19mm sliding bridgeplates for building the camera system for high-end studio work. The bridgeplate configuration can accept Aaton, Arri, Chrosziel and other manufacturers' mattebox, follow focus and support equipment that is designed for bridgeplate use.

Standard bridgeplates from Aaton, Arri and other manufacturers can be attached to the XTRprod by means of the 3/8-16 tripod receptacle on the underside of the camera.

The sliding bridgeplate system is recommended when large 35mm lenses and accessories are to be used, when using a geared head or when the highest possible production value is necessary.

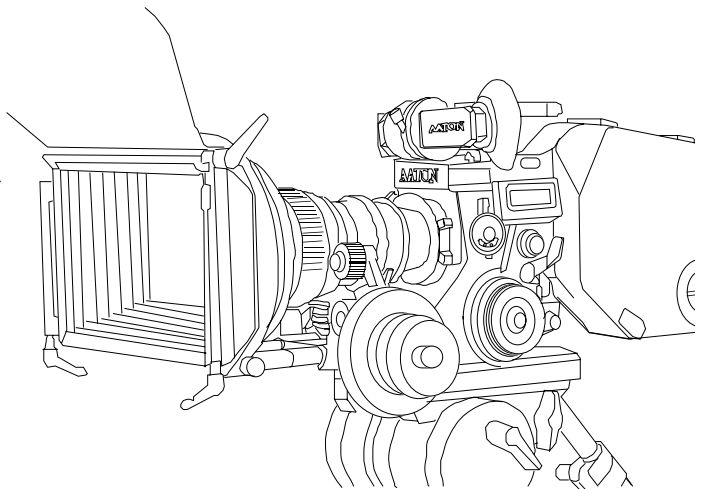

4.2 HANDGRIP

The XTRprod body includes a wooden handgrip, short 15mm rods, rod coupler and Lemo2 cable as standard. The handgrip, which is designed to be used for comfortable handheld operation, can also be used to provide on/off control on the battery side of the camera while on the tripod.

4.2.1 Mounting the Handgrip

Screw in one 15mm short rod into each of the two receptacles on the front housing of the camera below the lens port. Slide the coupler over the two rods to the desired location and fasten its center wing nut to secure the rods in position. Attach the handgrip to the coupler by mating the star plate on the coupler to that on the handgrip, adjusting to the desired position and fastening the T screw of the handgrip. Connect the Lemo2 cable between the handgrip and camera body to add on/off capability to the handgrip. The Lemo2 connector is located on the battery side of the camera at the front of the accessory box.

4.2.2 Handgrip On/Off Functions

Both camera run and test functions are available from the handgrip. While hand-holding the camera, pressing the rocker switch to the right provides camera run, pressing the switch to the left provides test. Unlike the body switch, the camera test position of the handgrip is a momentary switch. Pressing and holding the switch opens the shutter and advances the mechanism 1/2 frame. Pressing and immediately releasing this switch advances the mechanism one full frame at a 1/4 sec exposure time. This function allows the use of the handgrip as a simple intervalometer.

4.2.3 Handgrip Adjustments

The handgrip rotation should be adjusted for maximum handheld operating comfort. Loosen the T screw and rotate the handgrip at the star plate until a more comfortable position is found.

If a more extreme repositioning is required, whether it be for reasons of comfort or clearance in certain studio rig configurations, this can be achieved with coupler extenders, spacers and intermediate arms which utilize the star plate system for adjustment. Ask your agent for a configuration that meets your needs.

4.3 TRIPOD USE

In order to use the XTRprod on a standard tripod, the tripod's quick release plate must be fastened to the underside of the camera body with its standard 3/8-16 screw. Make sure to use only a quick release plate screw provided by the manufacturer; non-standard screws longer than 8mm (1/3") can fracture the base casting and damage the camera's electronics.

4.4 SHOULDER OPERATION

One of the most attractive features of the Aaton system has always been its comfort and ease of use in handheld situations.

The XTR line does not require the use of shoulder braces or additional padding for handheld operation. The contour of the camera and magazine is designed to fit snugly around the operator's shoulder. The wooden handgrip is attached to the front rod coupler at a slight angle to bring the operator's elbow into his side and increase stability.

The system can be completely built off the 15mm front rods without the use of a bridgeplate to allow for quick changing from shoulder to tripod operating modes.

4.5 CARRYING HANDLE

The carrying handle of the XTRprod is reinforced to safely accommodate any carrying, operating or mounting situation.

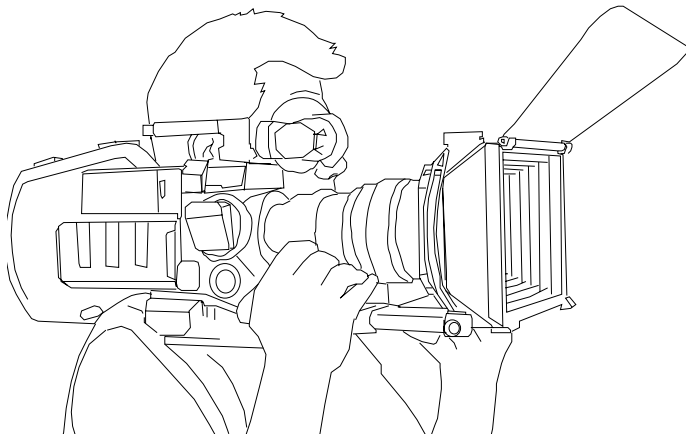

4.5.1 3/8 Accessory Screw

The handle features a 3/8-16 insert to receive accessories such as french flags and light-weight monitors. Be sure not to use a 3/8 screw longer than 10mm (7/16"); longer screws can fracture the insert casting and damage the viewfinder's optics.

4.5.2 Mounting from the

Carrying Handle

The 3/8 insert, along with a guide hole at the rear of the handle, can also be used to build a plate to undersling the camera or to configure the rig for Steadicam low mode use. For this reason, the handle features a long flat top surface that is parallel to the bottom of the camera.

4.5.3 Tape Measure Stud

The handle is also equipped with a hideaway tape measure stud, which is positioned between the rods directly behind the 3/8 insert. To use this stud, pull it up and fasten the ring of a standard assistant's tape measure around it; the stud holds the tape measure zero point precisely at the film plane.

4.6 TRANSPORT

One often overlooked, yet vital factor in the proper functioning and longevity of your camera equipment is your transportation practices. A few good shipping habits can avert potential damage caused by careless messenger services and airport handling.

When shipping and carrying your equipment, it is always good

practice to break down the package to its basic components whenever possible. Ship the body, mags and batteries unattached and individually padded. Never, under any circumstances, ship the camera with a lens attached (especially a zoom lens). Shocks transferred from the outside of a case could have disastrous effects to the ultra-critical back focus of a lens and flange focal distance of a camera if transported as one.

Make certain there is ample padding between individual components in a case and from the case's outer edges. Shipping case manufacturers suggest a minimum of 1 1/2" padding between high precision components such as the camera and lenses. 1" of padding is acceptable, however, between some of the more rugged components, such as magazines and batteries. Manufacturers also suggest to allow 2" of padding between the component and the outside of the case. Choose a case design that, not only meets your shipping and travel requirements, but allows you maximum flexibility and comfort out in the field. Check with your Aaton agent to determine the case configuration that best suits your needs.

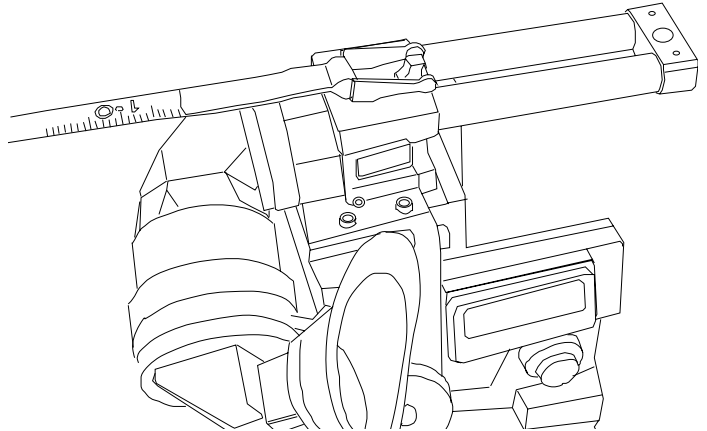

4.7 EXTREME CONDITIONS

Certain precautions should be taken in order to achieve maximum performance when operating the XTRprod in extreme or adverse conditions.

4.7.1 Cold weathers

The XTRprod features a built-in electronic heating element located in its base which is designed to automatically turn on when needed

and maintain the claw mechanism at a temperature of 15° F. One of the cold, hard facts of cold weather shooting is the considerable reduction of battery life. Do whatever possible to conserve your batteries and always carry more than usual. Favor many small batteries, such as on-boards and lithium cells (which are easier to keep warm), over large block batteries. Use a powercable so that the on-board battery could be kept in a pocket close to the warmth of your body.

When filming outdoors, use a standard or heated barney to protect the camera body from direct contact with the wind and cold. To avoid condensation inside the mechanism, electronics and lens elements, do not take the equipment indoors or expose it to sudden temperature changes. If and when the equipment must be moved inside, do so by first placing it in a sealed container and letting it thaw for a few hours before opening.

Always keep your raw stock and loaded magazines below freezing temperatures at all times during a cold weather shoot.

7.2 Warm Weather

To keep the temperature of the camera body down, avoid having the camera exposed to direct sunlight for long periods of time by using a barney, all-weather cover, or some form of shading, like an umbrella. Most importantly, keep raw stock and magazines in a dry cooler or in the coolest location available.

CLEANING

5



5.1 LENS

5.1.1 Lens Elements

The front and rear surfaces of your lenses should be ins-

Lens Cleaning Tips

Avoid handling lens tissue on the surfaces which will contact the lens. Oil from your hands transferred to the lens surface will make an easy cleaning job tough. Furthermore, never clean a lens element without the aid of cleaning fluid. A good number of scratches on lens surfaces are caused by poor cleaning methods.

ys kept clean of dust particles, smudges, and fingerprints. Blow off any large particles of debris using an air blower. The lens should then be cleaned using lens cleaning fluid. Apply a few drops of cleaning fluid to a clean lint-free cloth. Wipe the lens in a circular fashion, starting from the center and working towards the outer edge. Repeat the process until the lens is sufficiently clean.

The exterior of your lenses such be cleaned of dirt and adhesives as necessary. Use a multi-purpose cleaner or degreaser such as De-Solv-It applied with a Q-tip, lens tissue or cotton cloth.

5.1.3 Mounting Surface

Always inspect and keep the surfaces of your lens mounts clean using alcohol or a multi-purpose cleaner with a Q-tip. Remember, any debris found on the surface which contacts the lens seat can directly affect the back focus of your lens. Make sure the Q-tip does not leave any cotton fibers behind.

5.2 BODY

5.2.1 Exterior

Keep the external body surfaces clean using a cotton cloth with alcohol or a multi-purpose cleaner. Use a utility brush with soft bristles to clean dirt from tight crevices.

5.2.2 Mounting Surfaces

Like the lens mount, extra care should be taken to keep the lens

port ring completely free of dirt and debris. Clean this surface, as well as the threads of the lens lock ring using alcohol or a multi-purpose cleaner applied to a Q-tip.



Warning !

Remember, the camera gate is a sensitive and high precision area directly responsible for the exact focus of the image. Be careful not to use hard, damaging materials that conform to the groove Under no circumstances should you perform any type of cleaning operation, including the aperture opening, lens port or near the claw with power attached to the camera. Accidentally running the camera while performing such tasks can cause regions with no or just a few sprocket holes and mechanism.

5.2.3 Camera Gate

The gate should be cleaned of film particles by means of a pointed wooden or plastic orange stick. The tool used should be of a soft and pliable enough material (like wood) to conform to the groove side channels of the gate without breaking. Make sure to inspect and clean the left and right channels, the frame of the aperture opening, the lateral pressure plate, the tip of the claw and the timecode LEDs.

Afterwards, run your finger across the left and right rails of the gate, if your hands are clean. The oil from your fingers will provide just enough lubricant for the film to pass these surfaces smoothly. Inspect the gate; if the rails are still dirty or are carrying any debris (such as the adhesive from recanned rolls of film), with a Q-tip, use a cleaning fluid that will do the job. Alcohol and lens cleaner are safe to use on the surface of the gate. Make sure the Q-tip does not leave any cotton threads behind.



Cleaning the Mirror Shutter

Do not attempt to clean the surface of the mirror shutter; any small dust particles visible from the lens port will not come into focus in your viewfinder. If large particles of dirt must be removed, do so using an air syringe. Never use canned air on this surface. If the mirror is in need of a deeper cleaning, to remove smudges or oil, take your camera to a qualified technician to be cleaned.

5.3 VIEWING SYSTEM

The following components of the viewing system should be cleaned whenever dirt particles are visible through the viewfinder. Use lens fluid applied with a cotton tip preferably a foam Q-tip for all areas. By cleaning the viewing system in the order described below, you will clean the more dust-prone areas first, which may help you track down most dirt particles



sooner.

5.3.1 Viewing Screen

Finding the dirt

There is a simple means of locating much of the dirt within your viewing system: Look through the viewfinder with no lens on the camera and adjust the diopter ring. If the dust particles remain in focus, they are most likely located on either side of the eyepiece. If the dust comes in and out of focus as the ring is moved, the dust is probably located on either surface of the viewing screen. Furthermore, if the dust appears to be on the same focus plane as the cross hairs of the viewing screen, it is most likely on the bottom surface of the screen and easily accessible.

rt at
ing
utter
insi-
t the

our finger or by setting the camera to test the battery. Remove the viewing screen as Changing the Viewing Screen in the Came-
annual. Clean both upper and lower surfaces

ch is the outermost element closest to your rface with canned air, then cleaning with lens

fluid and a Q-tip. Remove the eyepiece and clean the field lens (B), which is located on the inside of the eyepiece, in the same fashion.

5.3.3 Viewfinder

With the eyepiece off, look into the remaining viewfinder and clean the exposed element of the pechan prism using canned air or an air syringe. If dirt particles are still present, remove the viewfinder assembly from the camera by removing the four allen screws that hold the base of

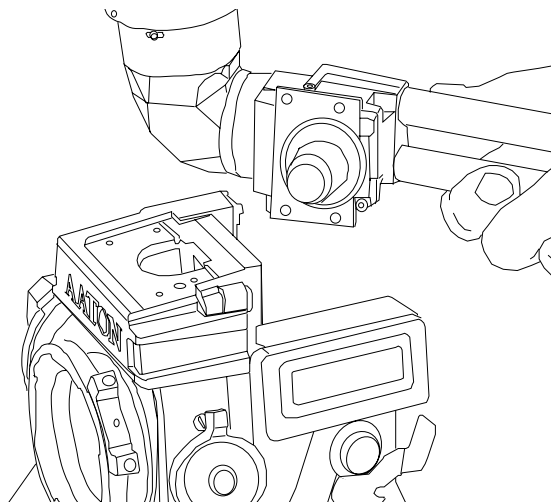
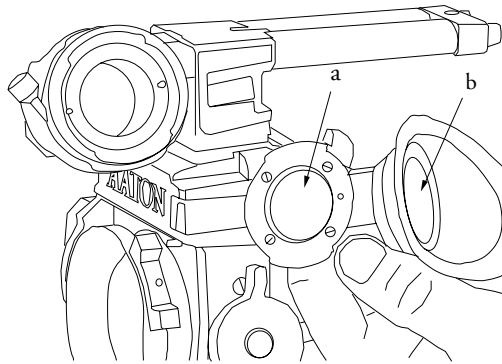

the viewfinder to the front housing. Clean the exposed underside element of the viewfinder.

5.4 MAGAZINE

5.4.1 Exterior

Keep the external surface of the magazines clean by wiping down with a cotton cloth with alcohol or a multi-purpose cleaner. When a deeper cleaning is necessary, use De-Solv-It rubbed into the mag's surface with a cotton cloth. Finish with alcohol applied with a cloth to restore its original finish.

5.4.2 Pressure Plates

The magazine pressure plates should be cleaned of dirt and film particles by means of a dust-free cotton or chamois cloth. After cleaning, run your finger across their surface for a slight lubrication.

5.4.3 Interior / Film Path

qOpen the doors of the magazine and inspect all surfaces on which the film rides. If any film dust buildup is apparent in the sprocket or roller areas, use alcohol and a Q-tip to clean. Use a utility brush with soft bristles to clean particles from tight crevices.

Afterwards, use canned air and thoroughly blow out any remaining dust in the throat and main chambers.

SUPER 16

6

6.1 SUPER16

6.1.1 The Format

Super16 is a means of utilizing the cost effectiveness of 16mm film for wide-screen applications. The 1.66 aspect of Super16 uses 20% more of the film surface by extending the picture into an area otherwise reserved for soundtrack or a second set of perforations. This increase in usable area results in significant improvements in image quality obtainable from 16mm film when used for any wide-screen application.

16mm standard *Super16*

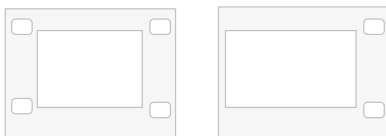

6.1.2 When to Shoot Super16

Generally speaking, Super16

can be a good choice of origination in the following instances:

- Any low-budget, theatrical production shot in 16mm for blow-up to 35mm.
- Any documentary or film that has the potential for future use in HDTV or some other widescreen aspect.
- Any 16mm production that has a long shelf life or would like to extend the shelf life of their film by making it wide-screen ready.
- Any 16mm commercial, music video or such that will be shown in the letterbox format.

6.2 GENERAL CONCERNS

6.2.1 Protecting the Negative

Specific precautions should be taken with any piece of equipment that handles the Super16 negative. The additional usable area of the film must be free from contact with transportation surfaces in all instances, whether it be in the camera, at the lab or on the telecine. The Aaton XTR camera series, since its debut in 1984, has been built for safe and trouble-free Super16 operation.

On the other hand, equipment that has not been designed with Super16 in mind may cause rub, scratch or pressure marks within the area once occupied by a second set of perfs. In order to be sure that a certain device is compatible with Super16, it is always best to check with the manufacturer or the facility responsible for the equipment.

6.2.2 Maintaining High Quality

When Super16 is to be used for 35 blow-up, for future HDTV purposes, or for any other medium of greater resolution than today's standard television, it is of utmost importance to use the appropriate equipment and develop practices that will ensure the high quality of your images. Slight imperfections, which very often pass undetected on an NTSC or PAL screen, are greatly magnified when viewed in a more demanding format.

The XTRprod, with a registration tolerance of 1/2000 of the image dimension both laterally and horizontally, delivers the most stable and exact imaging of any 16mm camera available.

Your Super16 images, however, will only be as sharp as the lenses you use to capture those images. It is not enough to choose a lens that merely covers the wider aspect of Super16; just as important are the attributes of a lens such as sharpness, contrast and zoom curve, which affect overall image quality. See the list of recommended lenses for Super16 use, in the Technical Specifications chapter.

The critical adjustment of camera and lens and their relationship to one another insures that the lens is achieving its optimum focus point at precisely the same distance as to where the film plane lies.

With the stringent requirements of Super16, it is recommended that camera flange focal distance (FFD) and lens back focus be checked and precisely upheld by a qualified service facility.

6.2.3 Ordering Film

When ordering raw stock from your distributor, make sure to specify Super16 or single perf film. In the US, where 16mm double perf film is manufactured as standard, it is recommended to check stock

of Super16 color negative 1-2 weeks prior to shooting. When ordering Super16 black & white stocks, it is advised to contact your distributor a month in advance when possible.

6.2.4 Film Processing

It is always recommended to choose a film lab that has a certain level of experience handling Super16. Make sure of the services they offer.

When preparing your film to be processed, be sure that your camera assistant has clearly indicated on the film cans and camera reports that the exposed film is Super16.

6.3 SHOOTING SUPER16

One of the most important aspects of shooting Super16 is achieving the full potential quality of the image. The best way to maximize image quality is to reduce the amount of perceptible grain within the picture. Factors such as film selection, exposure and processing techniques will affect the graininess of the resulting image.

6.3.1 Selecting a Film Stock

Relatively speaking, the faster the stock, the more grain there will be. Therefore, it is recommended to use stocks rated at 200 ASA and below whenever possible.

6.3.2 Lenses

The characteristics of any given zoom lens, those which determine image quality, contrast and sharpness, are most critical at wide angle and wide open aperture. In order to achieve the best image quality and the greatest depth of field, favor the longer focal lengths and T stops of 4 and above, when possible.

6.3.3 Lighting

It is recommended not to cut corners with your lighting package for

the sake of the budget. Those scenes which rely in the speed of the lens to compensate for minimal lighting will produce more grain than scenes which are amply lit and use a less critical lens aperture (T4 and higher).

6.3.4 Exposure

When shooting Super16 for blow-up, avoid underexposure and push-processing whenever possible. In fact, slight overexposure of the negative will produce a blow-up with less grain and increase color saturation and detail in shadowed areas. For best results, it is recommended to overexpose the negative anywhere from 1/3 to one stop, depending on the stock and the desired look.

When shooting Super16 for video transfer, slight overexposure is recommended for the same reasons, but care must be taken. Overexposed negatives on a telecine require a higher gain, which increases video noise. The benefits of an overexposed negative, however, outweigh the additional noise introduced if the overexposure is kept within one stop or less.

6.3.5 Camera Moves

If a Super16 film is to be viewed on a large screen, any camera movement becomes intensified. Therefore, it is best to keep camera moves subtle and handheld activity more controlled than when shooting in 35mm.

6.4 SUPER16 FIELD CONVERSIONS

All XTR cameras, including the XTRprod are capable of both 16mm and Super16 operation. These cameras are designed to be field convertible; switchable between formats by the user in a few simple steps. The following section offers detailed instructions on this procedure.

- For easier identification, the Super16 position of all adjustments will be marked with red dots, standard 16 position will be unmar-

ked.

- All references to alignment in these instructions are made looking at the port of the camera from its front, unless otherwise noted.

6.4.1 Before You Begin

Before attempting a field conversion, make sure you have the following tools on hand:

- 1 small slotted screwdriver
- 1 loupe - approximately 5x magnification.
- 1 standard metric Allen L-wrench set - sizes delivered with camera
- 1 orange stick
- 1 Port Alignment Tool * - part #09-100-62 for Aaton Port, #09-100-61 for PL Port

You'll also need the following equipment:

- 1 Battery, preferably with XLR4 powercable
- 1 Zoom lens

The conversion should be performed on a clean workbench or table by an individual who is somewhat mechanically inclined.

4.2 Procedure

- 1. Changing the Viewing Screen

The XTRprod features an interchangeable viewing screen which allows the user to install a screen with the 16 or Super16 aspect markings of his choice. See section Changing the viewing screen to proceed.

- 2. Checking Screen Centering

It is advisable to check that the newly-installed screen is properly centered to the aper-

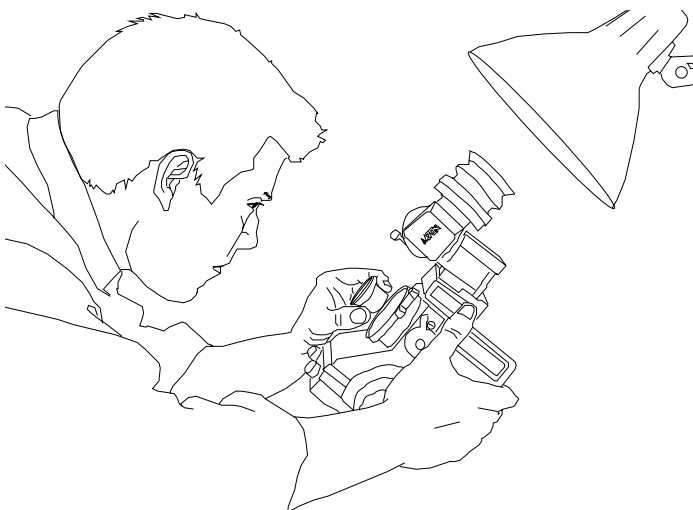

ture opening.

Remove both the port cap and the aperture cover. Power the camera, preferably using a powercable so that a battery is not onboard.

Open the eyepiece shutter and direct light into the eyepiece by pointing its opening at a desk lamp or an overhead light source.

Situate the body so that the lens port is angled to face you. Run the camera at normal speed; the opening of the aperture plate should be easy to detect. If this is not the case, place a white piece of paper behind the camera in your field of view.

With a loupe, closely inspect the frame area. If the light through the eyepiece is strong enough, you should be able to see the reflection of the viewing screen superimposed over the aperture opening when the camera is running. If this is not the case, adjust the amount of light through the finder by moving the eyepiece in or out of the

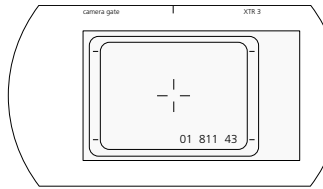
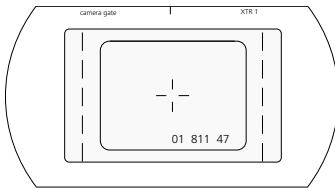

light.

When both the viewing screen and aperture opening can be distinguished, check that the viewing screen image is properly aligned to the

aperture opening (indicated below in grey).

Regardless of the screen or format, the entire full frame indicated on all screens, should be centered to the entire aperture opening of the camera gate.

The tolerance for this alignment is approximately the thickness of a line of the screen. If the viewing screen does not seem to be aligned properly, check its seating by pressing against the threaded hole with your thumb.

• 3. Shifting the Viewfinder

The viewing optics of the camera need to be set to the new optical center of the shifted viewing screen.

Remove the viewfinder assembly from the camera by removing the four allen screws and spacer that hold the base of the viewfinder to

the front housing. Take note of the side on which the spacer has been removed. The spacer is used to fill the gap that is created when shifting the viewfinder between formats. Replace the viewfinder assembly accordingly:

Secure the viewfinder by installing the spacer on the appropriate side and installing the four screws loosely. After all four screws are in place, tighten each screw until it is snug.

• 4. (a) Shifting the PL Lens Port

The PL lens port needs to be reset to the new optical center of the shifted viewing screen and viewfinder.

If the port cap is on, remove it. Notice that there are six slotted screws which lock the lens port ring to the lens holder, each with an unoccupied hole alongside it. Also note that one of each pair of holes will be marked with a red dot indicating Super16 positioning. Remove the six screws and carefully lift off the lens port ring and its accompanying shims and place on a clean surface with the shim side face up. Take note of the screw holes from which the six screws have been removed. Also note an unoccupied hole alongside each.

Shift the lens port by refastening the lens port ring utilizing the second set of screw holes on both the lens port ring and the lens holder. The clockwise-side holes on both are for standard 16 positioning, the counter-clockwise holes are for Super16.

Carefully replace the lens port ring and its shims, and install the six screws in the appropriate holes as detailed in the diagram below. Be sure not to damage the shims; take extra care to align their cutouts around the holes to be used. Fasten the screws, then loosen each 1/2 a turn in preparation for fine centering.

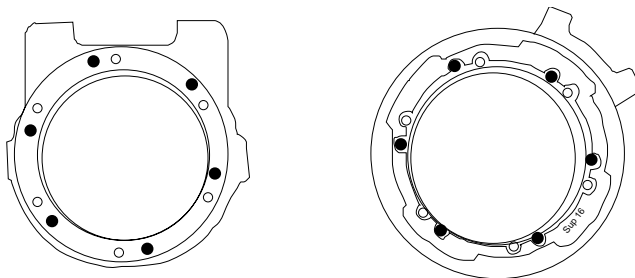

• 4. (b) Shifting the Aaton Lens Port

- *Super 16*
- *16 Standard*

Follow the procedure below if your camera is equipped with an Aaton lens port.

If the port cap is on, remove it. Remove the lens stop knob by loosening the single slotted or allen screw which secures it to the lens lock ring.

Remove the lens lock ring by unscrewing it off the lens port ring. Take a look at the lens port ring. Notice that there are three allen head screws which lock the lens port ring to the lens holder, each with an unoccupied hole alongside it. Also note that one of each pair of holes will be marked with a red dot indicating Super16 positioning.

Remove the three allen screws and carefully lift off the lens port ring and its accompanying shims and place on a clean surface with the shim side face up. Take note of the screw holes from which the three screws have been removed. Also note an unoccupied hole alongside each.

Shift the lens port by refastening the lens port ring utilizing the second set of screw holes on both the lens port ring and the lens holder. The clockwise-side holes on both are for standard 16 positioning, the counter-clockwise holes are for Super16.

Carefully replace the lens port ring and its shims, and install the three allen screws in the appropriate holes as detailed in the diagram. Be sure not to damage the shims; take extra care to align their cutouts around the holes to be used. Fasten the three screws, then loosen each 1/2 a turn in preparation for fine centering.

- 5. Fine-Centering of the Lens Port.

There are two methods by which to set the exact centering of the lens to the viewing screen. Both methods are equally acceptable.

Method 1 - via the Port Alignment Tool

The port alignment tool consists of the alignment jig and the centering rod.

Check that the screws of the lens port ring are loose enough that the ring can move independently of the lens holder.

Clear the mirror shutter as described in Step 1 so that it is rotated safely inside the body and the aperture opening could be seen from the lens port opening. Make sure that the battery is removed from the body before proceeding further.

Remove the centering rod from the alignment jig and position the jig over the lens port ring with the jig's engravings facing out. Make sure the alignment jig is flush against the surface of the lens port ring.

While holding the jig in place and looking at the aperture plate, carefully slide the appropriate side (16 / Super16) of the centering rod through the jig and into the port until it peeks through the outside of the aperture plate. If the centering rod is not centered to the aperture plate and cannot slide through its opening, gently move the lens port ring until it can do so.

For 16 centering, you'll notice that the 16 end of the centering rod is narrower than the aperture and can easily fit in place. In this case, make sure that the right edge of the centering rod is flush against the right edge of the aperture opening.

For Super16 centering, make sure the Super16 end of the centering rod fits evenly through the aperture opening.

When the centering rod is aligned accordingly, firmly secure the screws of the lens port ring.

On Aaton lens ports, replace the lens lock ring by screwing it onto the lens port ring until it stops, then backing it off until the lock stop knob screw hole is at the 2 o'clock position. Install the lock stop knob and secure its screw.

Install the port cap to check that the lens lock ring functions properly.

Method 2 - via Lens Tracking

Replace the lens lock ring and lock stop knob as described immediately above.

Check that the three allen screws of the lens port ring are just loose enough that the ring can move independently of the lens holder.

On a piece of paper, draw a + mark in the center of the page that

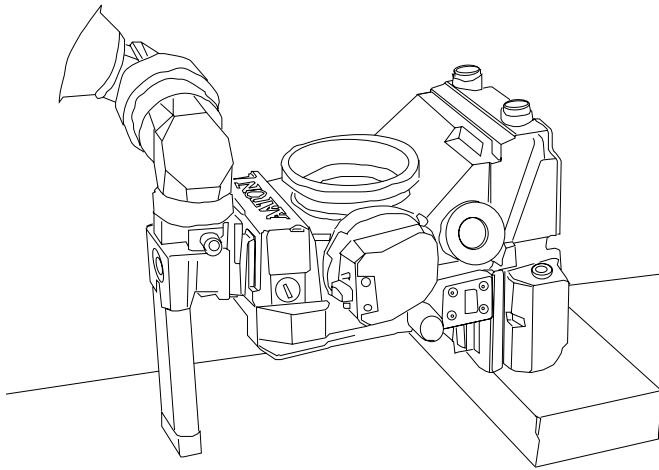

extends out to its edges so that the page is divided into four equal quadrants. Tape or pin the paper to the ceiling directly above your working surface.

Position the camera body underneath the paper target with the lens port facing up towards the target. Use a block of wood or a spacer of sorts to position the camera so that the lens port is approximately

parallel to the ceiling.

Select the zoom lens that will be used most frequently with the camera; preferably the lens in your kit with the longest zoom ratio. Mount the lens on the camera and tighten the lens lock ring moderately.

Look through the viewfinder and set the zoom of the lens to its full telephoto position. Focus the lens on the target and reposition the camera body so that the center of the viewing screen cross-hair exactly matches the center of the target.

Set the zoom to complete wide-angle position and notice that the center of the target with relation to the viewing screen cross-hair will track off in one direction. Without moving the camera steady, reposition the lens and lens port ring until the target is centered. Using an allen L wrench, carefully tighten the screws enough to secure the lens port ring.

Set the zoom lens to telephoto position and check that the crosses remain centered. If this is not the case, reposition the body, loosen the screws slightly and repeat the above procedure. You will find that, with each adjustment, you will come closer to the correct lens centering.

When the cross on the target matches and holds its center through

the entire zoom range, firmly secure the screws. The target cross should keep within the inside edges of the viewing screen cross-hair to be considered in tolerance through the range.

- 6. Realigning the CCD Assist Target

The CCD assist needs to be repositioned and refocused to be properly aligned to the new optical center. See section 12.4 of the Camera Body chapter to proceed.

AATONCODE

7

7.1 CONCEPT

AatonCode, Aaton's proprietary in-camera timecode system, is recorded in the XTRprod on the edge of the film between the perforations in both matrix and man-readable form. As recorded in the camera, AatonCode contains a six digit production ID, a SMPTE-compatible real time address (full date and time), a camera equipment ID and the running speed of the body.

Timecode is exposed onto the film by means of seven micro-diodes, which flash rapidly to form the code as the film rolls through the gate. The intensity of the diodes is adjusted to the film's sensitivity by means of the camera's ASA selection.

The XTRprod can accept timecode information in both ASCII and SMPTE form, and work with all standard timecode devices.

Because the same time address is running in both the camera and the sound recorder, a slate is no longer needed for syncing purposes; synchronization becomes fully automatic during the film/tape transfer or later post-production stages.

An Aaton device called Keylink, which consists of CCD reader heads and a PC, and which is owned by the telecine house, is designed to read Keycode and Aatoncode off the film during transfer and correlate this to the continuous video timecode and all other colorist entries for storage on its hard drive. Keylink can also ingest scene/take information and notes from the set recorded by means of Aaton's Script Supervisor software.

The facility can then supply all correlated information in VITC (vertical interval timecode) and/or burn-in windows on the transferred tape, and also on floppy disk for direct use with non-linear editing systems, audio workstations and logging programs.

7.2 THE INTERNAL CLOCK

The XTRprod contains an internal clock designed to be initialized from an outside source and keep accurate time (within a half a fra-

me) for 8 hours. After 8 hours of keeping time, the yellow diode on the base of the XTRprod will flash once every four seconds, indicating that accurate time is no longer guaranteed.

In order for the internal clock to operate, the camera must be powered before initialization. The camera is also equipped with an instantly charged supercapacitor buffer that is designed to keep time between battery changes. Keep in mind that a battery which is too low to run the camera has enough energy to drive the internal clock for hours. Get into the habit of leaving an exhausted battery on-board the camera until you have a fresh battery close by. The supercapacitor allows a full minute for battery replacement before timecode is lost.

7.3 ORIGINPLUS

For the most efficient and foolproof means of working with AatonCode, it is highly recommended that an Aaton device called OriginCplus is used. OriginCplus can be quickly programmed with a production ID, full date and time of day, then initialize timecode devices in either ASCII or SMPTE form. OriginCplus is TCXO-controlled and will run for 150 hours with an internal 9V lithium cell; it is designed to be left on during the shoot day and used as a comparator to monitor timecode drift between devices.

OriginCplus can also be used as a SMPTE generator to supply accurate timecode for slates and inserters, or to record timecode on one audio channel of a non-timecode audio recorder.

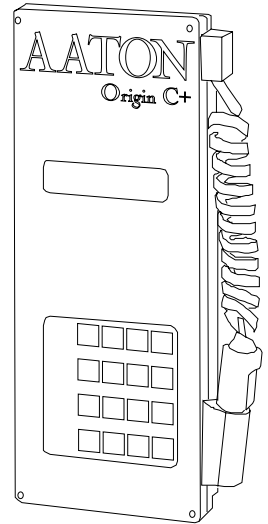

7.4 INITIALIZING AATONCODE IN THE CAMERA

There are two ways in which AatonCode can be initialized in the XTR-

prod camera. The preferred method is by means of the OriginCplus, which inputs timecode in ASCII form. It is also possible for the camera to receive information in SMPTE form directly from a SMPTE timecode device such as an TC audio recorder. Both methods are detailed below.

7.4.1 Using the OriginCplus - Recommended Method • Program the OriginCplus by inputting Prod ID, accurate date and time of day. Press the # key to scroll through each field; after all fields are set as desired, Press * to start the clock.

- Make sure the camera has a battery attached.
- Plug the Lemo5 cable of the OriginCplus into Lemo5 chassis mount on the base of the camera. On the XTRprod, the Lemo5 connector is located on the motor side to the lower left of the motor.
- Press * on the OriginCplus to send the timecode information. The OriginCplus will display Good 00.0 after the timecode has been accepted by the camera. Likewise, the small yellow diode on the camera base will blink to indicate running timecode. Also, the control panel of the XTRprod will display hours/minutes/seconds when the button marked time is selected. Toggling this button will also display year/month/day, then the production ID, then the equipment #.

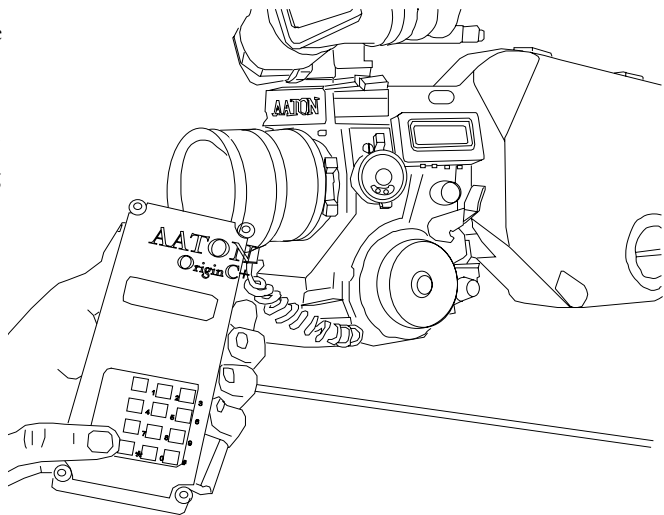

- Make sure to adjust the ASA selection to the exposure index of the film stock being used.
- Disconnect the OriginCplus from the body and proceed to the

next device.

For further details on the OriginCplus, please refer to the publication entitled OriginCplus - Initializing and Monitoring Aaton Timecode.

7.4.2 Using an External SMPTE Device

- Make sure the XTRprod has a battery attached and is not running.
- Choose the SMPTE timecode device that will be supplying the timecode (such as a Fostex PD2 or a Nagra IVS-TC). Set the time of day and date, and set its clock to free run mode.
- Connect a cable from the SMPTE output of the timecode device to the Lemo5 chassis mount on the base of the camera.
- Set the on/off switch on the camera to run or test position, then off again; this will send the timecode information to the camera body. The small yellow diode on the camera base will blink to indicate running timecode. Also, the XTRprod will display hours/minutes/seconds when the button marked time is pressed. Toggling this button will also display year/month/day and the camera's equipment #. No production ID will be recorded.
- Disconnect the cable from the body and proceed to the next device.

7.5 MONITORING AND MAINTAINING AATONCODE

After initialization, the OriginCplus should be left on during production to act as a visual reference and for quick drift monitoring. Once timecode has been initialized into the camera(s) and sound recorder, accurate time will be individually maintained in each machine for six hours. It is suggested, however, that new timecode be re-initialized after four hours or so as a precautionary measure. Get into the habit of using the OriginCplus to monitor timecode drift in each device when possible; every 2-3 hours or so is recommended.

7.5.1 Monitoring AatonCode with OriginCplus

Assuming that the OriginCplus has been left on during the production, follow the simple procedure below to monitor drift in the camera.

- Plug the Lemo5 cable of the OriginCplus into the Lemo5 chassis mount connector at the base of the camera.
- Press * to monitor AatonCode drift. OriginCplus will compare its own timecode to that of XTRprod. OriginCplus will display Good, fair, bad or dif-time (different time) followed by the amount of drift in tenths of a frame.
- Follow the same procedure for each camera or sound recorder on the set running AatonCode. When initializing or monitoring timecode in a SMPTE device, press *0 on the OriginCplus.

7.5.2 Maintaining AatonCode without OriginCplus

If the OriginCplus has not been used and timecode has been set in the camera directly from the TC audio recorder, there is no way to monitor timecode drift between the two devices. In this case, it is recommended to simply re-jam the camera every two to three hours. Follow the procedure detailed in section 4.2 Using an External SMPTE Device

Make sure that the camera on/off is switched to run or test position for it to accept the newly fed code.

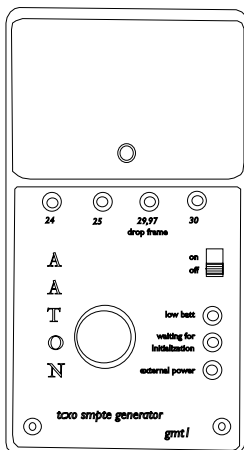

7.6 GMT I

Because more and more cineasts are using sound recorders not specifically designed for cinema, which means with no integrated timecode, Aaton needed to modify its OriginCplus: now, OriginCplus is able to serve as a SMPTE generator, which you can connect to any sound recorder.

But OriginCplus may be too big and too powerful for such an usage. So Aaton deci-

ded to built the GMT1, a mini SMPTE generator also designed to provide a timecode track for any sound recorder. The GMT1 is smaller than the OriginCplus, and it can work continuously for 150 hours with just a standard 9V battery. Its timecode informations (time and date) can be initialized with any SMPTE generator as with OriginCplus.

To choose the timcode frequency you need (according to the speed of your camera), remove the battery cover and turn the small white cross, beside the 9V battery, with a screwdriver. You can choose between 24, 25, 29.97 and 30 fps. To each choosen frequency correspond one LED, which flash every second.

You can also use the GMT1 as an OriginCplus supplier: if one day, by mistake, you have forgotten to take your OriginCplus with you, then use the GMT1 to initialize timecode in your camera. The GMT1, with no timecode initialized inside, is still able to generate a SMPTE code, starting at 1h 00mn 00s.

7.7 THE CAMERA ASSISTANT'S DUTIES

Although timecode-related practices on the set are very straightforward and uncomplicated, there are a few duties which should be handled by the camera assistant as part of his / her routine.

7.7.1 Checking the Diodes

In order to inspect and clean the gate between magazine rolls, the camera must be set to test position. Not only will test position rotate the shutter 180°, but the seven timecode LEDs in the gate will illuminate in a three/four sequence. Use this pattern to occasionally check that all diodes are operational and evenly illuminated. As part of the normal gate cleaning procedure, clean this area with a Q-tip and lens cleaning fluid to assure that no dust particles cover the LED array.

The seven diodes will illuminate in test position whether or not timecode is running in the camera.

8.7.2 Setting the ASA

When changing magazines, make sure the ASA/ISO setting of the camera matches the film stock being used. To check the current ASA selection on the LCD control panel, press the button marked ISO twice . To adjust the ASA setting, press SET, then this button. Make your selection between 25 and 1000 ISO by toggling the button or by rotating the jog wheel.

7.7.3 Checking for Running Time

The yellow LED located to the right of the motor, will flash once per second on the second when timecode is running in the camera. Get into the habit of looking for this flash as an additional peace of mind check. If more than one camera is counting time on the set, check that all flashes occur simultaneously.

TECHNICAL SPECIFICATIONS

8

TECHNICAL SPECIFICATIONS

Weight 6kg / 13 lbs with 400 ft load and 12V on-board battery.

Power 10-14 V, 600 mA, with film à 25°C / 77°F.

Temperature range -20°C / +4°F to +40°C / +104°F.

Noise level 20 dB -1/+2.

Speeds preset speeds of 6, 12, 18, 20, 23.98, 24, 25, 29.97, 30, 36, 40, 48, 60 and 75 fps. Built-in variable crystal control from 3 to 75 fps in 0.001 increments.

Image stability Co-planar claw and lateral pressure. Vertical and lateral steadiness to 1/2000 of image dimensions.

Viewing screen Interchangeable fiber optical screens available in 1.33, 1.66, 1.78 (16/9) and 1.85 aspect ratios and combinations thereof. Aatonite illuminated markings.

Lens port Interchangeable hard fronts: ArriPL as standard. Aaton universal and Panavision on option.

Shutter Reflex mirror - multi-position 180°, 172.8°, 150°, 144°.

Formats 16 / Super16 operation. Field-convertible quick centering of lens axis, viewfinder and CCD target between formats.

Time recording AatonCode; in-camera, at-the-gate matrix recording of man-readable figures and machine readable data. TCXO control for 1/2 frame accuracy over 8 hours internal clock. SMPTE and ASCII-RS232 in.

Accessory inputs Amph9 (video sync), Lemo6 (power zoom), Lemo8 (phase controllers), Lemo14 (CCD assist), Lemo5 (Smpete and RS232 time input) and Lemo2 (camera on/off).

Video assist (option) Black & white - low power (170mA) high sensitivity, integrated CCD assist with manual iris. PAL or NTSC formats. Color - high sensitivity, flicker-free (frame-store in NTSC), integrated CCD assist with timecode windows, video generated adjustable frame and Vitc insertion. PAL or NTSC formats.

Magazine 400 ft, coaxial instant DX magazine, quick loading, magnetic drive, no timecode-related parts.

LCD control panel Illuminated display. Pre-set and variable speed selection, ASA selection, battery voltage monitoring, remaining footage, short end reset, elapsed footage, mag ID, full timecode readout.

Warnings Low speed, problem with the magazine, low battery, end of film coming soon.

8.2 CONNECTOR - PIN ATTRIBUTIONS

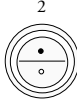
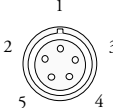
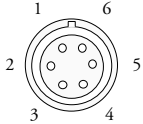
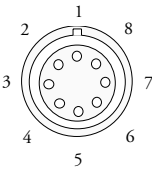
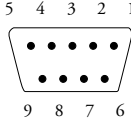
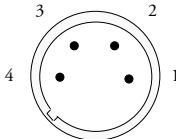
Type	Fonctions	Diagram	Localisation	Pin Attributions
<i>Lemo2</i>	On/Off/Test		<i>Between the two motors. Looking down.</i>	1 Ground 2 Start
<i>Lemo5</i>	TimeCode Interface		<i>Under jog wheel.</i>	1 Ground 2 Smpte In 3 ASCII In/Out 4 et 5l <i>Not used</i>
<i>Lemo6</i>	Power Zoom		<i>Above the right motor.</i>	1 -Batt 4 +Batt 6 Start 2, 3 & 5 <i>Not used</i>
<i>Lemo8</i>	Speed Controllers		<i>Above and to the right of the left motor.</i>	1 -Batt 2 TV Sync 3 ASCII In/Out 4 +Batt 5 100 PFF Out 6 Start 7 100 PFF In 8 Ground
<i>Amph9</i>	Video Sync		<i>Above the left motor.</i>	1 -Batt 2 TV Sync 3 2400 Hz 4 ASCII In/Out 5 +Batt 6 -Batt 7 Strobe 8 Start 9 +Batt
<i>XLR4</i>	Power In		<i>Above the jog wheel.</i>	1 -Batt 4 +Batt 2 et 3 <i>Not used</i>

● pin ○ socket

*Do not hook accessoires consommant more than 2 amps

AVAILABLE VIEWING SCREENS

